

Please note, this PDF is a scan of the original course textbook that has been edited with OCR for text recognition. Feel free to copy and paste from the text, but please be aware that there may be errors in the text recognition.

# **DISCIPLESHIP**

by

**Milton Martin**

)

)

.

)

# TABLE OF CONTENTS

## SECTION I

	Page
<b>THE NEED FOR REPRODUCERS</b>	3
<b>SUCCESSFUL DISCIPLING</b>	5
<b>CHAIN OF MULTIPLICATION</b>	6
<b>DISCIPLESHIP PRECEPTS</b>	7
<b>DISCIPLESHIP PRECEPTS</b>	8
<b>THE TRAINING OF THE DISCIPLES</b>	9
<b>PRACTICAL ASPECTS OF SPIRITUAL NURTURING</b>	11
<b>DISCIPLING</b>	12
<b>BIBLICAL DISCIPLESHIP</b>	13
<b>SOME GOALS FOR DISCIPLES</b>	15
<b>THE LOST ART OF DISCIPLE MAKING</b>	17
<b>SALVATION IS FREE BUT DISCIPLESHIP COSTS EVERYTHING WE HAVE</b>	18
<b>REASONS FOR INDIVIDUAL DISCIPLING</b>	19
<b>PROFILES OF A CONVERT, DISCIPLE, WORKER AND LEADER</b>	20
<b>MAN TO MAN</b>	21
<b>A BIBLICAL PROFILE OF A DISCIPLE</b>	23
<b>CYCLE OF LEADERSHIP - (ILL.)</b>	24
<b>CYCLE OF LEADERSHIP</b>	25
<b>THE LORDSHIP OF JESUS CHRIST</b>	26
<b>THE PIE ILLUSTRATION</b>	28
<b>LEADERSHIP</b>	29
<b>A DISCIPLE IS A LEARNER</b>	30
<b>PURITY OF LIFE</b>	34
<b>A DISCIPLE IS A SERVANT</b>	37
<b>ESTABLISHING A DISCIPLE IN A FELLOWSHIP OF BELIEVERS</b>	40
<b>WHAT IS THE KEY TO WORLDWIDE EVANGELIZATION?</b>	42
<b>WHY PEOPLE ATTEND THE CHURCH THEY DO?</b>	45
<b>CHARACTERISTICS THAT MUST BE IN OUR LIFE</b>	46

<b>CRITERIA FOR FAITHFUL MEN</b>	49
<b>A PARENT HEART</b>	50
<b>QUOTES TO REMEMBER</b>	52
<b>THE NEEDS OF A BABY</b>	53
<b>THE DYNAMICS OF PERSONAL FOLLOW-UP</b>	54
<b>THINGS TO REMEMBER IN PERSONAL DISCIPLING</b>	57
<b>BUILDING DISCIPLES</b>	58
<b>BASICS FOR MOTIVATION</b>	62
<b>HOW TO STUDY THE WORD OF GOD</b>	64
<b>RUN THE RACE</b>	66
<b>HOW TO RUN THE RACE</b>	67
<b>THREE WAY TEST FOR SUCCESS GOALS</b>	71

# TABLE OF CONTENTS

## SECTION II

	Page
THE PLAN OF SALVATION	2
AN EXAMINATION OF SALVATION	3
ASSURANCE OF SALVATION	4
GOD HAS PROMISED TO YOU	6
RESOURCES FOR VICTORY IN THE CHRISTIAN LIFE	7
CHRISTIAN GROWTH - PART I	8
CHRISTIAN GROWTH - PART 2	9
JESUS CHRIST IS THE SUPREME WONDER OF THE BIBLE	11
LEARNING TO PRAY	12
HAVING DEVOTIONS	13
PRAYER POSSIBILITIES	14
WORLD WIDE STRATEGIC INTERCESSION	15
THE IMPORTANCE OF THE BIBLE	16
GETTING THE WORD INTO THE LIFE	17
HOW TO HEAR GOD'S WORD AND REMEMBER	18
THE BIBLE IS A BOOK OF PRINCIPLES AND PROMISES	19
PURPOSEFUL BIBLE READING	20
"HOW READEST THOU?"	22
MORNING - NEW TESTAMENT	23
BUILDING DISCIPLES	30
DAILY BIBLE READING NOTES	32
WHY MEMORIZE SCRIPTURE	33
OBEDIENCE	34
GOD'S PURPOSE FOR MAN	35
GROWTH OF THE CHURCH	36
CHECKLIST FOR VICTORY	37
DISCERNING GOD'S WILL	38
WALKING IN THE WILL OF GOD	39

<b>PRINCIPLES OF GUIDANCE</b>	40
<b>CONDITIONS FOR VICTORY</b>	42
<b>POWER FOR LIVING</b>	43
<b>CRUCIFIXION</b>	44
<b>CHARACTERISTICS OF A PERSON OUT OF FELLOWSHIP WITH THE LORD</b>	45
<b>THE LOST ART OF DISCIPLE MAKING</b>	46
<b>HOW TO HAVE SOMETHING IN HEAVEN WHEN YOU GET THERE</b>	47
<b>THE PIE ILLUSTRATION</b>	50
<b>HOW TO DOUBLE YOUR LIFE EFFECTIVENESS</b>	51
<b>FIVE PEGS FOR SCHEDULING TIME</b>	53
<b>DISCIPLESHIP PRECEPTS - ORGANIZATION</b>	54
<b>DISCIPLESHIP PRECEPTS</b>	55
<b>THE SEVEN GIFTS OF ROMANS 12</b>	56
<b>MY SPIRITUAL INVENTORY</b>	58

**SECTION I**

**LESSONS FOR DISCIPLES**

)

)

)



# THE NEED FOR REPRODUCERS

Matt. 28:18-20, II Tim. 2:2

The world is looking for better methods, God is looking for better men.

Every Christian should be producing more Christians, every preacher should be producing more preachers and every church should be producing more churches.

Reproducers will only be produced through a definite program of discipleship.

Discipling others is the process by which a Christian with a life worth imitating commits himself for an extended period of time to a few individuals who have been won to Christ, the purpose being to aid and guide their growth to maturity and equip them to reproduce themselves in a third spiritual generation.

## I. Great Commission - Two Parts.

- A. Going - evangelizing - Mark 16:15; Luke 19:10; I Tim. 2:4,6; II Peter 3:9.
- B. Teaching - making disciples - Matt. 28:19-20.

## II. Why this method?

- A. It was the method of Jesus. Men were His method - Mark 6:31; 9:30-31.
- B. Discipleship was Paul's method - Acts 20:4,27. Elders, preachers, key leaders - all Asia Minor - I Thess. 1:6-8.
- C. It is Biblical - Moses disciplined Joshua  
Elijah disciplined Elisha  
Philip the Ethiopian, the Ethiopian to the Africans  
Paul - Silvanus, Timothy - Thessalonians - Macedonia - the World.
- D. Discipleship is the fastest way to fulfill the Great Commission. It is multiplication versus addition.

Illustrations:

Suppose you had your choice of salaries on a job, 1 cent doubled each day for 31 days or \$10 a day straight.

1<sup>st</sup> day - 1 cent  
2<sup>nd</sup> day - 2 cents  
3<sup>rd</sup> day - 4 cents  
4<sup>th</sup> day - 8 cents

5<sup>th</sup> day - 16 cents  
6<sup>th</sup> day - 32 cents

31<sup>st</sup> day - over 5 million dollars

Suppose a father offered his son the choice of allowance of 1 cent per week doubled or \$1 per week. One dollar a week is \$52 a year. One cent doubled each week by the end of the 52<sup>nd</sup> week is 22 trillion, 517 billion, 998 million, 136 thousand, 852 dollars and 48 cents.

Multiplication is EXPLOSIVE.

Suppose that it was possible to take a checkerboard, put one grain of rice on the first square and double it for each succeeding square. By the time you reach the last square you would have enough rice to cover the country of India to a depth of 50 feet.

Compare the difference in an evangelist winning 1,000 souls per day and a discipler producing one reproducer a year and each one reproduced, reproduces himself.

Year	Evangelist - 1,000 per day	Discipler - one per year
1	365,000	2
2	730,000	4
10	3,650,000	1,024
20	7,300,000	1,048,576
184	67,160,000	?

The discipler could reach the present world population in 32 years. It would take the evangelist 10,960 years. II Tim. 2:2; Isa. 8:16; 60:22.

### III. Why Should We Be Committed To A Ministry Of Multiplication?

- A. Brevity of life - vapor, blade of grass, cloud, tale that is told, water poured on the ground.
- B. Sense of stewardship. Life is precious and we have a responsibility - Ps. 66:8,9.
- C. I want my life to count! It was said of an old couple in the book "Human Bondage", "It was as if they had never lived at all." I don't want that to be said of me. What about you?

# SUCCESSFUL DISCIPLING

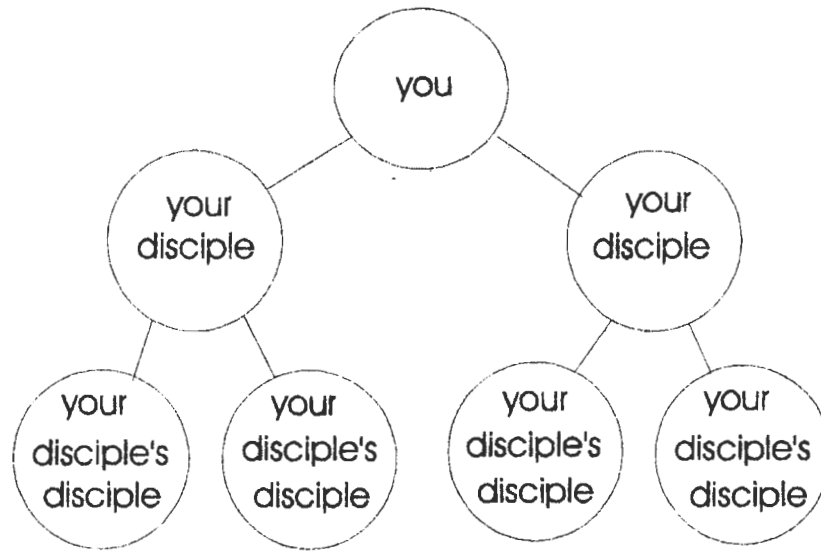

A person (you) who is committed to the task of reproducing his life in someone else (your disciple), who in turn will reproduce himself in a third spiritual generation.

“You” are the first generation, “your disciple” is the second generation, and “your disciple’s disciple” is the third generation.

## Examples of multiplication

Several Scripture passages clearly show the multiplication process. Second Timothy 2:2 says, “And the things that thou hast heard of me among many witnesses, the same commit thou to faithful men, who shall be able to teach others also.” How many generations are represented in this verse? Four! Second Timothy 2:2 could be charted like this:

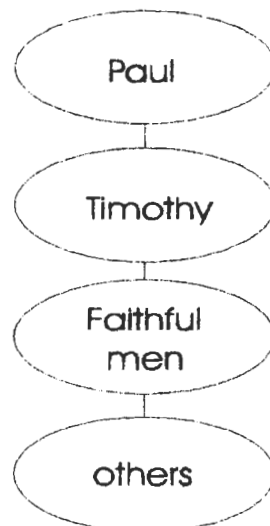

### YOU CAN MULTIPLY YOURSELF

Consider the "Chain of Multiplication," Figure B, which shows spiritual reproduction in the New Testament.

### CHAIN OF MULTIPLICATION

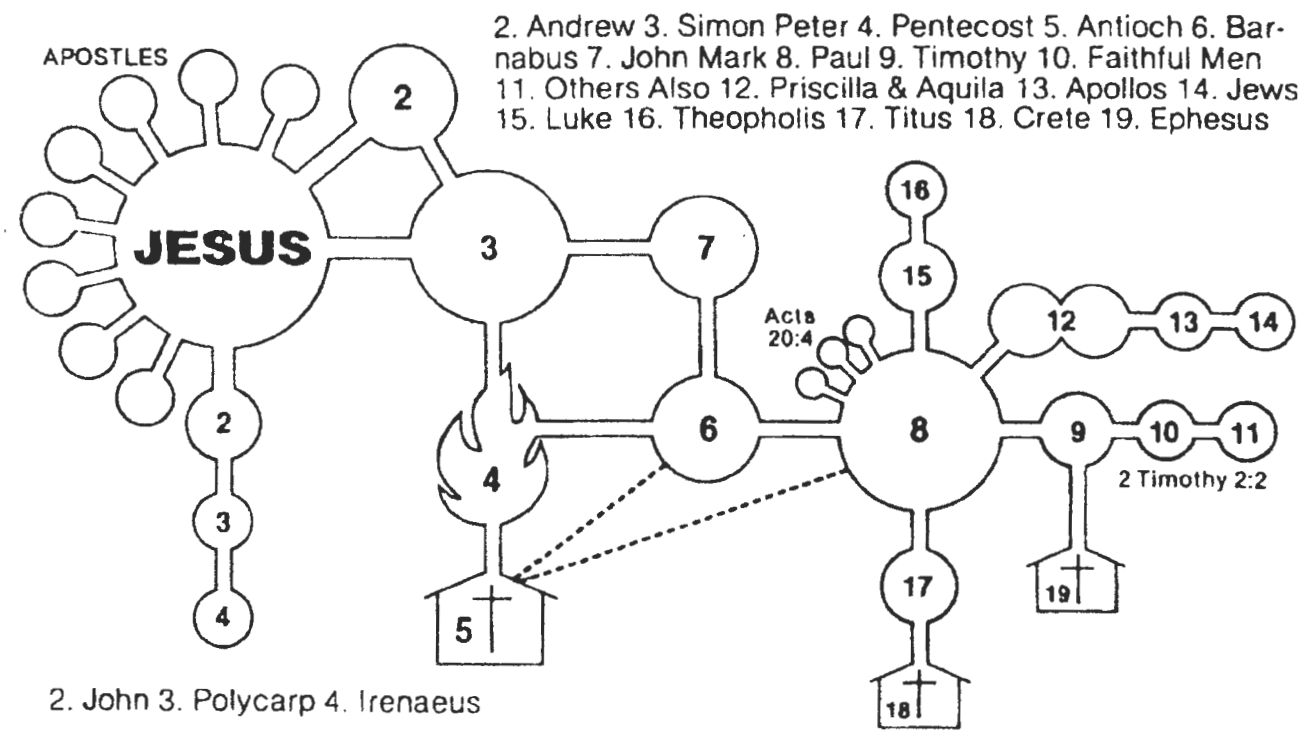

Figure B

## DISCIPLESHIP PRECEPTS

I'd rather see a sermon than hear one any day.  
I'd rather one should walk with me than merely show the way.

The eye's a better pupil and more willing than the ear;  
Fine counsel is confusing, but example's always clear;

And the best of all the preachers are the men who live their creeds,  
For to see the good in action is what everybody needs.

I can soon learn how to do it, if you'll let me see it done.  
I can watch your hands in action, but your tongue too fast may run.

And the lectures you deliver may be very wise and true;  
But I'd rather get my lesson by observing what you do.

For I may misunderstand you and the high advice you give,  
But there's no misunderstanding how you act and how you live.

Edgar A. Guest

When you get what you want in your struggle for self  
And the world makes you king for a day,  
Just go to a mirror and look at yourself,  
And see what the man has to say.

It isn't your father or mother or wife.  
Whose judgment on you must pass,  
The fellow whose verdict counts most in your life  
Is the one staring back from the glass.

You may be a Hack Horner and chisel a plum,  
And think you're a wonderful guy.  
But the man in the glass says you're only a bum  
If you can't look him straight in the eye.

He's the fellow to please - never mind all the rest.  
For he's with you clear up to the end.  
And you've passed your most dangerous, difficult test  
If the man in the glass is your friend.

Author Unknown

## DISCIPLESHIP PRECEPTS

I'd rather see a sermon than hear one any day.  
I'd rather one should walk with me than merely show the way.

The eye's a better pupil and more willing than the ear;  
Fine counsel is confusing, but example's always clear.

And the best of all the preachers are the men who live their creeds,  
For to see the good in action is what everybody needs.

I can soon learn how to do it, if you'll let me see it done.  
I can watch your hands in action, but your tongue too fast may run.

And the lectures you deliver may be very wise and true,  
But I'd rather get my lesson by observing what you do.

For I may misunderstand you and the high advice you give,  
But there's no misunderstanding how you act and how you live.

--Edgar A. Guest

When you get what you want in your struggle for self,  
And the world makes you king for a day,  
Just go to a mirror and look at yourself  
And see what the man has to say.

It isn't your father or mother or wife,  
Whose judgment on you must pass,  
The fellow whose verdict counts most in your life  
Is the one staring back from the glass.

You may be a Jack Horner and chisel a plum,  
And think you're a wonderful guy,  
But that man in the glass says you're only a bum  
If you can't look him straight in the eye.

He's the fellow to please—never mind all the rest.  
For he's with you clear up to the end.  
And you've passed your most dangerous, difficult test  
If the man in the glass is your friend.

--Author Unknown

# The Training of the Disciples

## Purpose of the Training

The purpose of their training was to prepare them to be Evangelists, or church-planters. Our Lord did not prepare them to be Elders or Pastors of churches. Their work was to be like His work, they were to evangelize. They were trained for aggressive work, for going out to meet the foe and to storm him in his citadels. Such was to be the work of the leaders of the Church. They founded churches, but they never remained as Elders of local churches. As leaders they must lead forward to conquest and extension. The immediate care of the local churches was to be the responsibility of local men with gifts for local ministry.

## Ten Essentials

In the preparation of the disciples our Lord evidently gave particular attention to the following points:

1. He was continually seeking their spiritual development. He made full use of all their experiences to teach eternal values. We have but to think of the occasion when the mother of James and John came seeking the highest places for her two sons, and the manner in which He dealt with the individual difficulties of Peter, Thomas and Philip, to realize how careful and watchful He was regarding the spiritual condition and progress of each one. It was the happenings of every day experience, the temptations and faults and failures of the disciples, that He used as the basis for this instruction. And how wisely and lovingly He did so! Here also theory was learned in the practical school. He brought them to the place where they were willing to deny self and to take up the Cross and truly follow Him. Nothing less than that would have served His purpose.
2. He taught them to evangelize. The practical method which He used to train them to know how to meet men and deal with souls, how to preach and teach, has already been stated.
3. He taught them to know and use the Scriptures. He Himself was continually using them. All His teaching was based upon them; all His reasoning and arguments were derived from them. Here again the same method is employed: they learned to know and use the Scriptures by using them.
4. He taught them to have faith in God directly for the supply of all their material needs. He had left all to live among men and become the Saviour of the world; they left all to follow Him. He had not where to lay His head; and so it was with them. They left all and went forth with Him, possessing nothing and with no material resources, looking to God alone for the supply of all their needs, sharing together with the Master out of the common fund of God's supply, of which Judas was the treasurer. This accomplished four important things: it detached them from the world; it made them exercise faith; it obliged them to walk near to God; it caused them to be living

witnesses to God's power and faithfulness. These things were necessary to their witness.

5. He taught them to minister in the power of the Spirit alone and not to have recourse to ritual, ceremony, forms of service, programs, emotionalism, sentimentalism or any other human means to attract or influence. He revealed to them that the power that would draw men was the power of His Cross.
6. He taught them the life and ministry of prayer in the Spirit, though they entered into it only after the Holy Spirit had come to dwell in them.
7. He taught them to live and minister in absolute obedience to the will of God, withholding nothing for self but placing themselves entirely upon the altar.
8. He taught them to exercise unwavering faith, to doubt not but to have absolute trust in God and confidence in His power and faithfulness.
9. He taught them absolute love to God and absolute love to their fellow men, the love that serves, seeking nothing for self and counting it all joy and all gain to give all.
10. He taught them to work together, to cooperate as a group directed by the Spirit of God, none seeking the preeminence and all serving each other.



# PRACTICAL ASPECTS OF SPIRITUAL NURTURING

II Tim. 2:2

## **Definitions:**

*Follow-up* - The spiritual work of grounding a new believer in the faith.

*Personal follow-up* - The assuming of a one-to-one relationship by a mature believer with a new Christian for the purpose of aiding the new Christian's maturity and growth.

*Disciple* - A Christian who is growing in conformity to Christ, is achieving fruit in evangelism, and is working in follow-up to conserve his fruit.

*Discipleship Training* - The spiritual work of developing spiritual maturity and spiritual reproductiveness in the life of a Christian.

*Multiplier* - A disciple who is training his spiritual children to reproduce themselves.

*Multiplication* - Third generation discipleship training.

# DISCIPLING

- I. Discipling is one of the most strategic ways to have an unlimited personal ministry.**
- II. Discipling is the most flexible of ministries.**
- III. Discipling is the fastest and surest way to mobilize the whole body of Christ for evangelism.**
- IV. Discipling has more long-range potential for fruit than any other ministry.**
- V. Discipling will provide the local church with mature lay leaders who are Christ-centered and Word-oriented.**

# Biblical Discipleship

Matt. 28:19-20, II Tim. 2:2, and II Pet. 3:18

Our heart goes out to the afflicted child and his parents. We would not think of bringing a child into the world and not caring for him. In the spiritual sense we have been doing that. I Tim. 5:8 is just as applicable spiritually as physically. Heb. 5:11-14, I Cor. 3:1-3. It is not a sin to be a baby Christian but it is a sin to be a baby Christian all your life.

## I. Manifestations Of Immaturity. How Many Problems Do We Have In Churches Because Of Baby Christians?

- A. The immature are more interested in playing or being entertained - I Cor. 13:11.
- B. Immaturity manifests itself in egotism. It is the center of its world and nothing else matters. The only important thing for such a person is having his needs satisfied.
- C. The immature reveal themselves in their interest, concern and worry in the flesh and about the flesh.
- D. The immature lack responsibility.
- E. The immature lack gratitude. A child has to be taught to be grateful.
- F. The immature are offended very easily. They misunderstand very easily.

*The ministry is more than taking care of spiritual babies, burping them, changing their diapers and attending to their every need. Something is dreadfully wrong when people remain forever in their immaturity.*

## II. There Are Seven Stages In Establishing Someone In The Word Of God!

- A. "Grounded" - Digged in, planted, (born again of incorruptible seed) - "Babes in Christ" - I Cor. 3:1; I Peter 2:2
- B. "Settled" - Watered by the Word - "Little Children" - I John 2:12; 5:21
- C. "Be not moved away" - staked down by the doctrine of salvation - "Children" - I Pet. 1:14; I Thess. 2:11
- D. "Rooted" - Growing in Knowledge - "Young Men" - I John 2:13; Titus 2:6
- E. "Built Up" - Growing in Grace - "Fathers" - I John 2:14; I Cor 4:15
- F. "Stablished" - Perfected and Strong - "Elders" - I Pet. 5:1; James 5:14
- G. "Abounding" - Bearing Fruit - "Aged Men and Women" - Titus 2:1-10. Active Involvement.

## III. A Discippler Cannot Be What He Is Not And Cannot Impart What He Does Not Have.

I Cor. 4:16, I Thess. 1:7, I Tim. 4:12, Phil. 3:17, 4:9, I Peter 5:2-3. The ability to physically produce children does not make you a father. Like always produces like. Some of us have never produced reproducers. We have produced after our kind. What we produce reveals what we are.

## **VI. Paul Was Many Things To His Children.**

Salvation is a person. Follow-up is someone, not something. Discipling is a relationship. III John 4, I Cor. 4:14-16; II Cor. 11:1-2; 12:15; I John 1:3. Read I Thess. 2:1-20.

- A. Paul was a father- I Thess. 2:11; Gal. 4:19; I Tim. 1:2; Phil. 10.
- B. Paul was a nurse or nursemaid - I Thess. 2:7.

## **V. You Are Not Reproducing Why? What Will Keep Us From Reproducing Physically?**

- A. Not being married. Marriage is a union with another person. Salvation is union with Christ. Are you in union with Christ?
- B. Disease or impairment to some part of the body that is needed in the reproduction process. Sin in the spiritual realm will make it impossible to be a reproducer.
- C. Immaturity. Little children cannot have babies.

Would you be honest with yourself and God in facing facts and reality in your life? Have you won souls to Christ? Where are they spiritually? How many reproducers have you produced? If you cannot do it with your own people in your own tongue, what makes you think you can with foreigners from another culture and language?

# SOME GOALS FOR DISCIPLES

John 15:16

## I. The Lord Said We Are To:

- A. "Go" v. 16b Going is always related to obedience.
  - 1. The commission cannot be fulfilled without going.
    - a. "Behold, a sower went forth to sow." Matt. 13:3
    - b. "Go ye therefore into the highways." Matt. 22:9
    - c. "Go ye therefore and teach all nations." Matt. 28:19
- B. "Bring forth fruit." V. 16b. Bringing forth fruit is always related to evangelism or soul winning.
  - 1. The going is for the reaping.
    - a. "Go out quickly (urgently)...and bring in hither." Luke 14:21
    - b. "Go out... and compel them to come in." Luke 14:23.
    - c. "Jesus said, Come ye after me and I will make you to become...fishers of men." Mark 1:17.
    - d. "One soweth and another reapeth, I sent you to reap." John 4:37,38.

*And then the Lord says to us, "and that your fruit should remain".*

## II. How Can We Assure That Our "Fruit" Remains?

- A. It is true that:
  - 1. Many converts do not follow in baptism.
  - 2. Many do not become faithful in church.
  - 3. Many eventually fall by the wayside.
- B. Why is that?
  - 1. Because they have weak roots - tree.
  - 2. Because they have a weak foundation - building.
  - 3. Because they were not established in the Word of God.

## III. An Absolute Necessity - Believers Must Be Established In The Word Of God Immediately.

- A. Necessary steps to fulfilling the Great Commission.
  - 1. "Go ye". - Matt. 28:19a.
  - 2. "Baptizing". - Matt. 28:19b.
  - 3. "Teaching them to observe all things." Matt. 28:19c.

Most churches fulfill the first two points - evangelism and baptism - but fail to complete the third and last part, "teaching them."
- B. Paul fulfilled all the Great Commission.
  - 1. Paul spent time to teach. Acts 18:11.
  - 2. Paul separated the disciples at Ephesus and taught for two years. Acts 19:8-10.
  - 3. Paul was not able to spend much time with the Thessalonians but sent Timothy. I Thess. 3:1-10.
    - a. They were exhorted to remember what they had been taught. II Thess. 2:15.

- b. Paul reminded the Corinthians to be faithful in that which they had been taught as well. I Cor. 11:2
4. The most used verse in relation to discipleship is the one Paul gave Timothy. II Tim. 2:2.

## THE LOST ART OF DISCIPLE MAKING

Shining is always costly. Light comes only at the cost of that which produces it. An unlit candle does no shining. Burning must come before shining. We cannot be of great use to others without cost to ourselves. Burning suggests suffering. We shrink from pain... "The glory of tomorrow is rooted in the drudgery of today." Many want the glory without the cross, the shining without the burning, but crucifixion comes before coronation.

Following these remarks was a poem that struck a responsive chord in my heart.

Have you heard the tale of the aloe plant,  
    Away in the sunny clime?  
By humble growth of a hundred years  
    It reaches its blooming time;  
And then a wondrous bud at its crown  
    Breaks into a thousand flowers,  
This floral queen, in its blooming seen,  
    Is the pride of the tropical bowers,  
But the plant to the flower is sacrifice  
    For it blooms but once, and it dies.

Have you further heard of the aloe plant,  
    That grows in the sunny clime;  
How every one of its thousand flowers,  
    As they drop in the blooming time,  
Is an infant plant that fastens its roots  
    In the place where it falls on the ground  
And as fast as they drop from the dying stem  
    Grow lively and lovely around?  
By dying, it liveth a thousand-fold  
    In the young that spring from the death of the old.

Have you heard the tale of the pelican,  
    The Arabs' Gimel el Bahr  
That lives in the African solitudes,  
    Where the birds that live lonely are?  
Have you heard how it loves its tender young,  
    And cares and toils for their good,  
It brings them water from mountain far,  
    And fishes the seas for their food.  
In famine it feeds them--what love can devise!  
    The blood of its bosom--and, feeding them, dies.

Have you heard this tale--the best of them all--  
    The tale of the Holy and True,  
He dies, but His life, in untold souls  
    Lives on in the world anew  
His seed prevails, and is filling the earth,  
    As the stars fill the sky above.  
He taught us to yield up the love of life  
    For the sake of the life of love.  
His death is our life, His loss is our gain;  
    The joy for the tear, the peace for the pain.  
Leroy Eims

## **"Salvation is Free But Discipleship Costs Everything We Have."**

"Would you spend as much time preparing yourself to meet the needs of one person as you would preparing a sermon for 5 thousand? How much do you believe in the potential of one?"

*"One living sermon is worth one hundred explanations."*

The new believer is a spiritual child and must have immediate parental care. Within 24 hours the convert should be prayed for, personally contacted, and shown how to begin feeding on the Word of God. A baby needs loving care and food.

Four methods of follow-up from I Thess. 1.

1. Personal Correspondence - I Thess. 1:1
2. Personal Intercession - I Thess. 1:2; 3:10; Rom. 16 (Paul lists 28 individuals or families) II Cor. 11:28.
3. Personal Representatives - I Thess. 3:1-5 (Timothy and at times Epaphroditus, Titus and others were sent), Phil. 2:22.
4. Personal Contact - Tender loving care by a more mature believer is an essential need of every convert. Satan fights this - I Thess. 2:18; 2:7,11.

*Discipling is done by someone, not something.*



## REASONS FOR INDIVIDUAL DISCIPLING

1. Anyone in the local church can do individual discipling. He simply shares with another what the Lord is doing in his life, and leads the other in the step which he has already taken.
2. Individual ministry is modeled in the church by personal counseling to the lost, sick, bereaved, discouraged, and those with expressed needs. It is equally logical to give quality time to people who desire spiritual growth.
3. Christ's ministry was to love his disciples and lay down his life for them (see John 13:1). Working with an individual captures the commitment of Christ to each of his men.
4. Few people have the time or capacity to be intimately involved in the lives of a number of individuals. Anyone can make time for working with one person.
5. Individual discipling has the closeness of friendship and the precision of an apprentice relationship.
6. It is flexible in scheduling, time frame, Bible study assignments, and training. These can be changed or paced according to individual needs. Spiritual growth is more rapid.
7. This method of individual discipling is readily copied. We do unto others what has been done unto us.
8. Exhortation, correction, and admonition are quickly and easily given in the setting of individual discipling.
9. The life of the discipler reinforces the truth of the message, and is in close view of the disciple.
10. The needs of the disciple surface in the privacy of individual ministry.
11. Both the relationship and the results seem more lasting in individual discipling.
12. Discipling on a one-to-one level is the most rapid way I know to develop spiritual leaders who can multiply disciples.

# **PROFILES OF A CONVERT, DISCIPLE, WORKER AND LEADER**

## **PROFILE OF A CONVERT.**

1. He gives evidences of possessing new life - II Cor. 5:17.
2. His attitude toward Jesus Christ is now favorable.
3. His attitude toward sin is now unfavorable.

## **PROFILE OF A GROWING DISCIPLE**

1. As a follower of Jesus Christ, he puts Christ first in the major areas of his life and is taking steps to separate from sin - Luke 9:23; Rom. 12:1-2.
2. He continues in the Word through such means of intake as Bible study and Scripture memory; he is regular in applying the Word to his life with the help of the Holy Spirit - John 8:31; James 1: 22-25; Ps. 119:59.
3. He maintains a consistent devotional life and is growing in faith and intercessory prayers - Mark 1:35; Heb. 11:6; Col. 4:2.
4. He attends church regularly and demonstrates Christian love by identifying with and serving other believers - Heb. 10:25; John 13:34-35; I John 4:2-21; Gal. 5:13.
5. He is openly identified with Jesus Christ where he lives and works, manifests a heart for witnessing, gives his testimony clearly, and presents the Gospel regularly with increasing effectiveness - Matt. 5:16; Col. 4:6; 1 Pet. 3:15
6. He is a learner who is open and teachable - Acts 17:11.
7. He is a visible follower and learner of Jesus Christ, and demonstrates consistency and faithfulness in all of the above areas - Luke 16:10.

## **PROFILE OF A WORKER**

1. He evidences growth in the virtues and skills outlined under Profile of a Growing Disciple - II Peter 3:18.
2. He shows a growing compassion for the lost and demonstrates his ability to lead men to Christ personally - Matt. 9:31-38; Rom. 1:6.
3. He is being used of God to establish believers who have become disciples, either personally or in a discipling group context - Col. 1:28-29.
4. He is currently engaged in the task of making disciples - Matt. 28:19. Regular intake of the Word by all means and the quiet time are now habits in his life - Phil. 4:9.

## **PROFILE OF A LEADER**

1. He is an equipped worker who evidences growth in the virtues and skills listed under Profile of a Worker.
2. He has been used of God to help disciples become workers - II Tim. 2:2.
3. He is banding and leading workers in evangelizing the lost and establishing believers - Mark. 1:38.
4. He displays faithfulness and integrity in his life and ministry - II Tim. 2:19-21 .

Is your current program producing a band of faithful people who are able to teach others? Is the method you have been using currently populating your church with a group of spiritually qualified workers? Would you rather have ten people established as disciples and equipped as workers or one hundred people partially so? Your answers to these questions will determine your philosophy of the ministry of making disciples.

**MAN TO MAN**

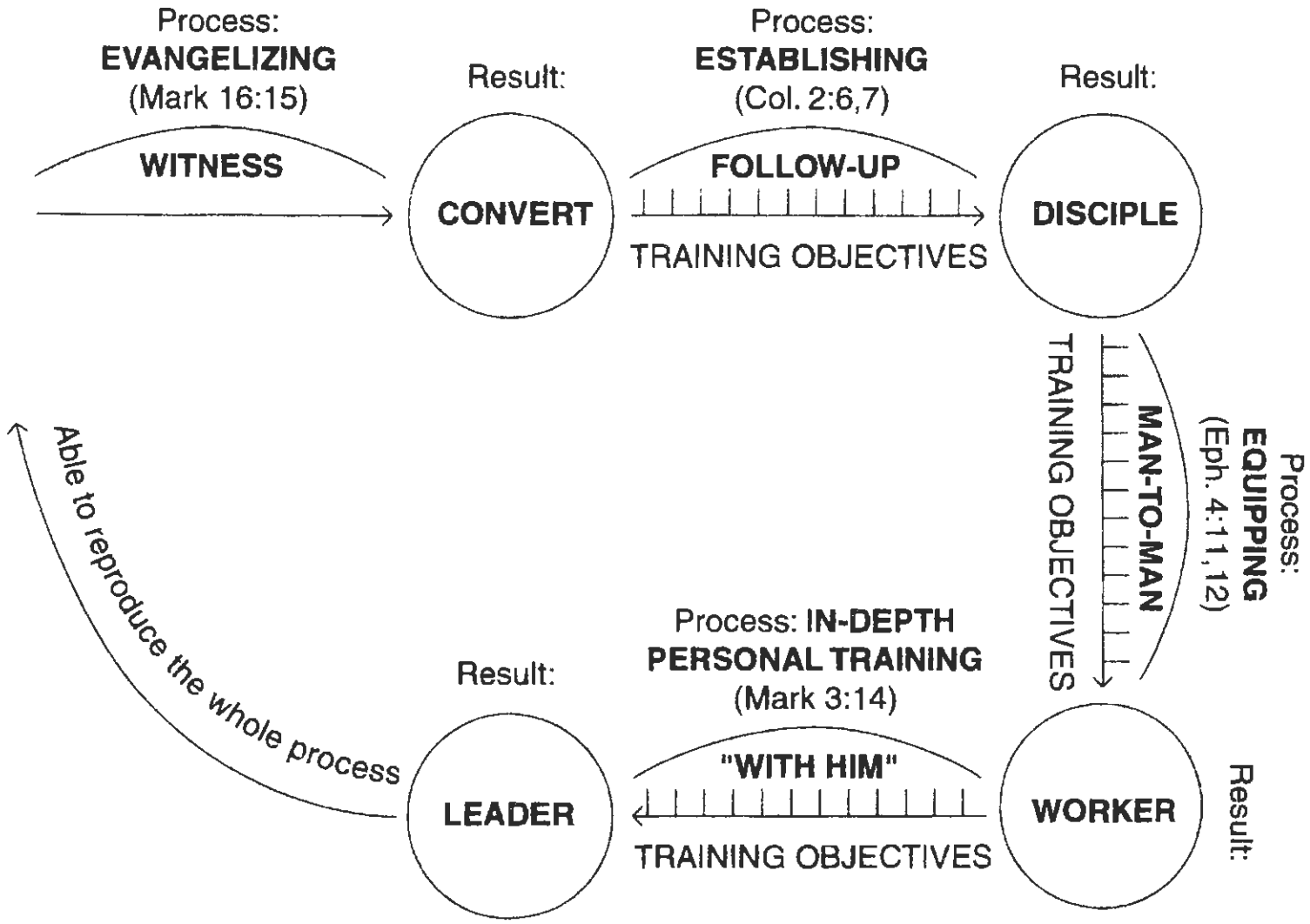

## **A BIBLICAL PROFILE OF A DISCIPLE**

1. A disciple is a learner - open and teachable - Prov. 9:8-10; Matt. 4:19; John 6:60-66.
2. A disciple puts Christ first in all areas of his life - Matt. 6:9-13,24,33; Luke 9:23; John 13:13; II Cor. 5:15.
3. A Disciple is committed to a life of purity and is taking steps to separate from sin - I Cor. 6:19-20; Eph. 4:22-5:5; Col. 3:5-10; I Thess. 4:3-7; Titus 2:12-14.
4. A disciple has a daily devotional time and is developing in his prayer life - Ps. 27:4; 42:1,2; Mark 1:35; Luke 11:1-4; I Thess. 5:17,18; James 1:5-7; 5:16.
5. A disciple demonstrates faithfulness and a desire to learn and apply the Word of God through hearing it preached and taught, reading it daily, Bible study, Scripture memory and meditation on the scriptures - John 8:31; Acts 2:42; 17:11; Col. 3:16; II Tim. 2:15.
6. A disciple has a heart for witnessing, gives his testimony clearly and presents the Gospel regularly with increasing skill - Matt. 28:18-20; Acts 1:8; 5:42; 14:21-23; 22:14,15; Rom. 1:16; I Cor. 15:3,4; I Thess. 2:4.
7. A disciple is one who is bearing fruit - not just talking about it - John 15:8.
8. A disciple attends church regularly to worship God, to have his spiritual needs met, and to make a contribution to a body of believers - Ps. 122:1; Acts 16:5; I Cor. 12:12-27; Col. 1:15-18; Heb. 10:25.
9. A disciple fellowships regularly with other believers, displaying love and unity - John 17:22-26; Acts 2:44-47; 4:31-33; Eph. 4:1-3; Heb. 10:24; I John 1:1-3.
10. A disciple demonstrates a servant heart by helping others in practical ways - Mark 10:42-45; Acts 6:1-4; II Cor. 12:15; Phil. 2:25-30; I Thess. 2:8,9.
11. A disciple is a tither, gives regular offerings and honors God with his finances - Haggai 1:6-9; Mal. 3:10,11; I Cor. 16:1,2; II Cor. 8:9; Philemon 14.
12. A disciple demonstrates the fruit of the Spirit by an attractive relationship with Christ and his fellowmen - Acts 16:1,2; I Cor. 13:4-7; Gal. 5:22,23; I Peter 2:18-23; II Peter 1:5-8.

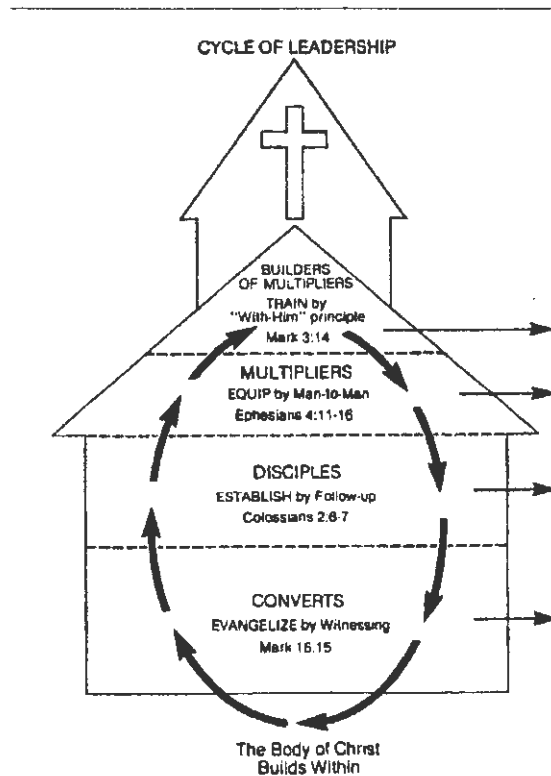

## INDIVIDUAL AND GROUP DISCIPLING

Producing leadership is a critical unmet need in the local church. Training in a group can be a starting point for developing leaders, but it has some limitations. However, personal disciplining one to one includes the personal involvement and commitment of time necessary to train leaders effectively. A biblical disciplining relationship should become a lifetime commitment to intercession and encouragement as the one we disciple grows.

Which one? Group or individual ministry? It is not either/or, but both. Individual disciplining is not a restrictive relationship. The same people can be involved in both ministries.

## REASONS FOR INDIVIDUAL DISCIPLING

1. Anyone in the local church can do individual disciplining. He simply shares with another what the Lord is doing in his life, and leads the other in the step which he has already taken.
2. Individual ministry is modeled in the church by personal counseling to the lost, sick, bereaved, discouraged, and those with expressed needs. It is equally logical to give quality time to people who desire spiritual growth.
3. Christ's ministry was to love his disciples and lay down his life for them (see John 13:1). Working with an individual captures the commitment of Christ to each of his men.

# CYCLE OF LEADERSHIP

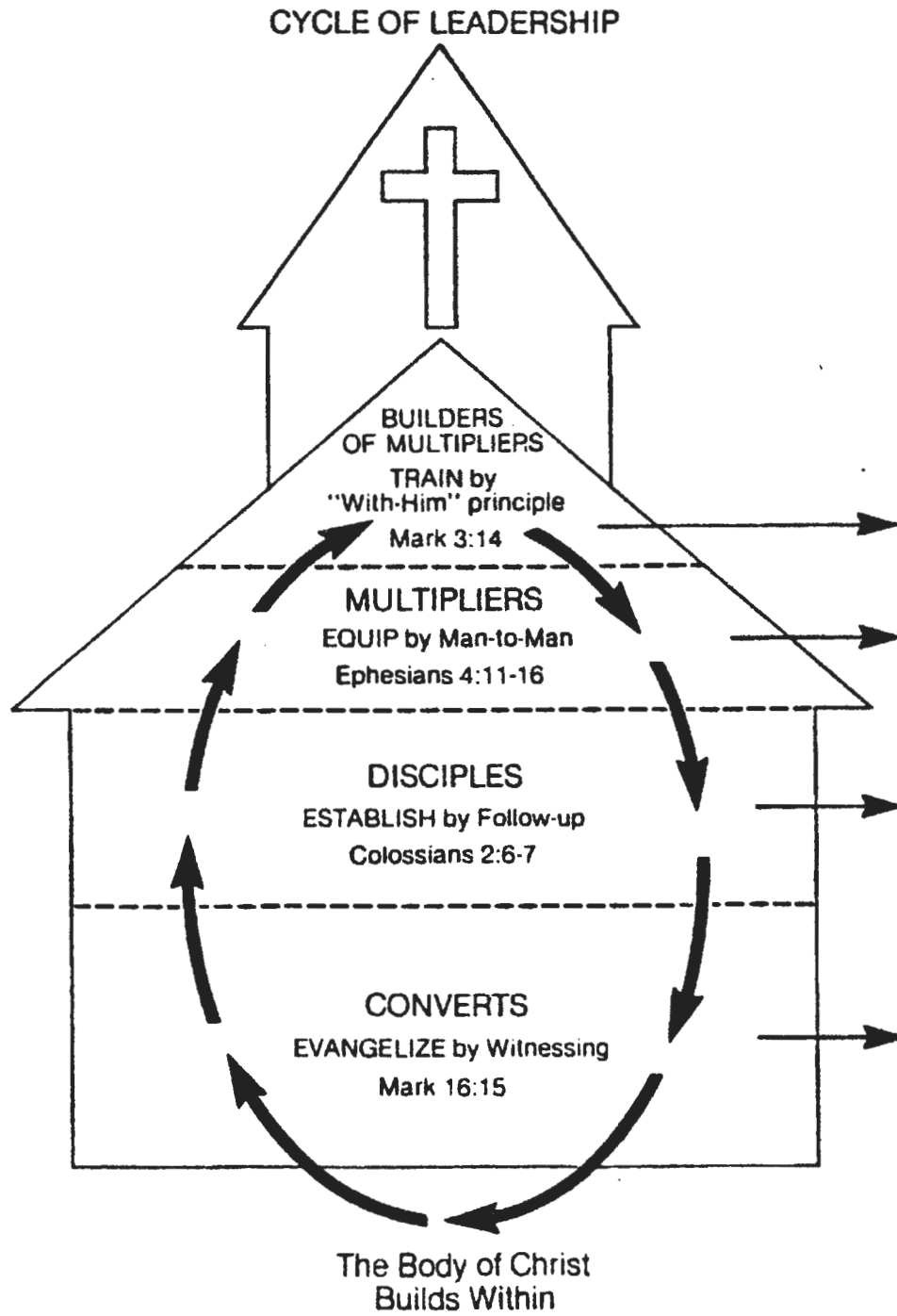

# THE LORDSHIP OF JESUS CHRIST

*A disciple puts Jesus Christ first in all areas of his life. Acts 2:36; Mark 12:29,30; John 13:13; Luke 6:46.*

## I. Jesus Christ As Lord.

By virtue of the fact that Jesus Christ is God, He already has authority over the universe and all creation.

### A. Who God is.

In order to acknowledge Him as Lord practically, we have to know what He is like. God is eternal, all-powerful, all-knowing, present every where, great, immutable, just, holy, loving and merciful. Yet all of these words together are not enough and fail to describe Him fully. I Chron. 29:11-13.

### B. He is Lord because of the salvation He secured.

The Lord Jesus Christ alone has provided the redemption necessary for all to have eternal life that choose to do so. His exalted position by the Father and His past and present work are at the heart of the issue of Lordship.

## II. Areas Where Jesus Christ Is Already Lord.

The Bible speaks clearly of a number of areas where Jesus Christ is head in practice.

### A. Jesus Christ is Lord over the angels. Heb. 1:4; Rev. 5:11,12.

### B. Jesus Christ is Lord over Satan. Col. 2:15.

### C. Jesus Christ is Lord over the nations. Ex. 9:16; Dan. 4:35.

### D. Jesus Christ is Lord over all creation. Col. 1:15-17.

1. Everything made is subject to the Lordship of Christ alone.

2. The only one that is not is man.

### E. Daily Lordship. Luke 9:23.

## III. The Plan Of Christ For His Disciples.

Jesus Christ, because He is Lord, has a plan for each of His children. In submitting to His Lordship, we realize His plan for our lives.

### A. Submission at all times.

1. God's plan for us is to be like Jesus Christ. II Cor. 3:18. Christ was totally submissive to His Father. John 4:34.

2. If we are to be like Jesus Christ, then we must be submissive to Him at all times. Rom. 8:29. (None of us can stand before God and say we have always done things that please Him. Our problem is centered in the heart where self-will struggles with the Lordship decision. God has promised us the power to overcome self. Romans chapter 6.)

### B. Submission of every area of our life.

The struggle of submitting to God in various areas of our life is always evident and is always a constant struggle.

1. "A clear and definite activity of the will is involved in recognizing His Lordship, since He is to be Lord of all. By her 'I will' at the marriage alter, the bride



ideally forever enthrones her groom in her affections. In subsequent years she lives out in detail all that was implied in that momentary act of the will. A similar enthronement of Christ can result from a similar act of the will, for the same decision that enthrones Christ automatically dethrones self."

J. Oswald Sanders *The Pursuit of The Holy*.

2. The whole principle of Lordship is the abdication of self on the throne of one's life, and the invitation to Jesus Christ to sit on the throne.

(Note the Pie Illustration on the following page).

C. The battle of submission.

When the decision is made to yield to the Lordship of Christ, a battle or spiritual struggle begins. We will be constantly opposed by Satan and our own will. Many are not willing to enter the battle.

People do not acknowledge Christ as Lord for many reasons.

1. "God may ask us to do something we do not want to do."
2. We think we know what is best for us.
3. We are not sure that God has our best interests at heart. Jerm. 29:11
4. We are afraid what we give to God may be taken away completely.

D. Stages of Obedience.

Obedience is tied into a Lordship decision. You cannot separate obedience and submission.

1. "I am going to do what I want to do no matter what God wants."
  - a. Many Christians realize that this attitude is wrong, but are determined to live according to this pattern.
  - b. Essentially this attitude is saying that Christ will not rule their lives.
2. "If God will give me what I want first, then I will give Him an equal exchange."
  - a. This is bargaining with God. I will give Him what I think is an equal exchange.
  - b. "If God will only give me the job that I want, then I will give Him some of my time in exchange."
3. "If God will give me what I want first, then I will give Him what He wants."
  - a. This is also bargaining with God.
  - b. It is self that is still first and on the throne of the heart.
4. "I will give God what He wants first, then in faith believe that He will give me what I want."
  - a. This has reversed the "me-first" approach, but it is still a form of bargaining.
  - b. It says, "I am expecting God to do something for me because I have done something for Him."
5. "I will give God whatever He wants, regardless of whether He gives me what I want."
  - a. This is Lordship in practice.
  - b. This is the crucial stage in our obedience.

The fullness of Christian living can only be known when Jesus Christ is Lord. I challenge you at this time to evaluate your life and be sure you are totally, unconditionally submitted to the Lordship of Jesus Christ.

## THE PIE ILLUSTRATION

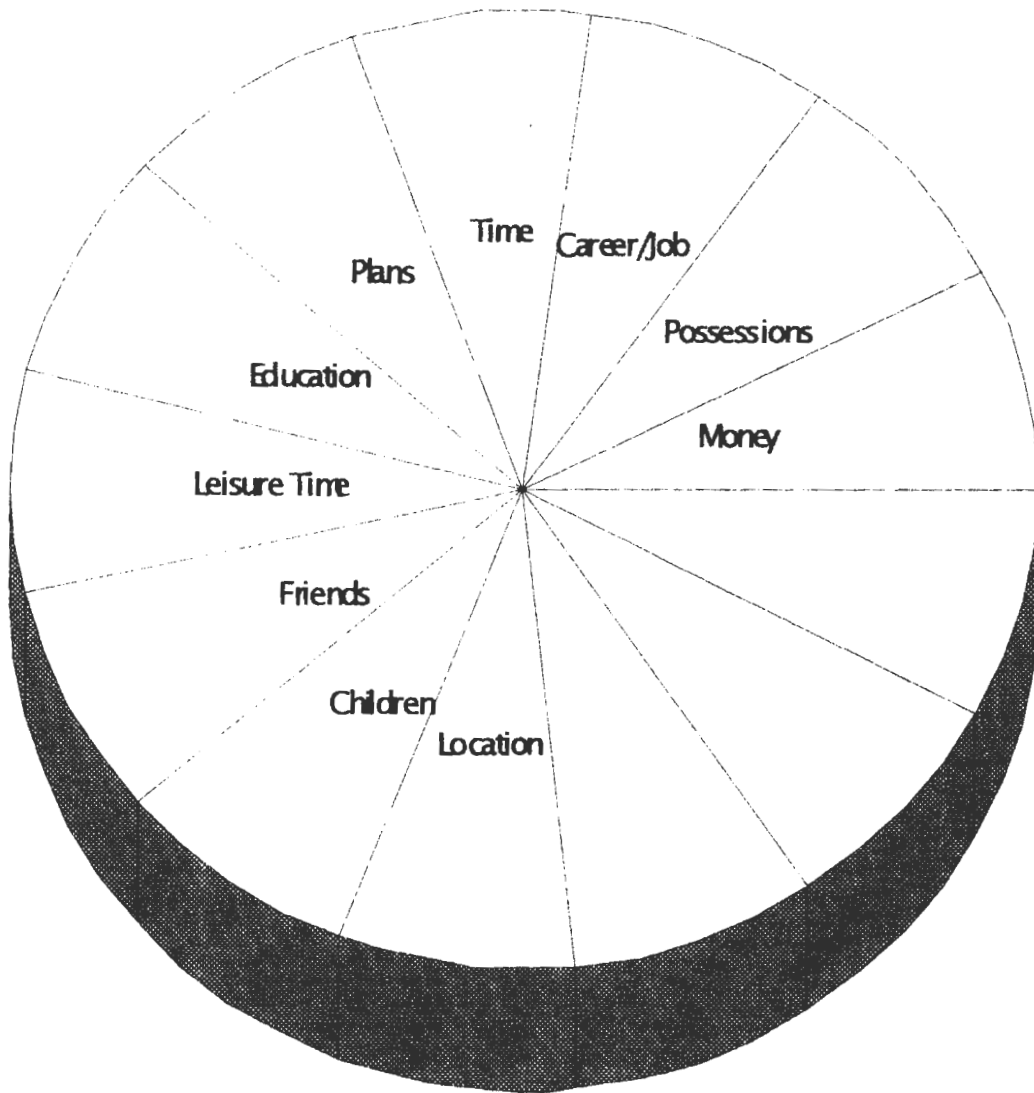

The Pie Illustration Communicates the issue of the Lordship of Christ. Each segment of the "pie" represents a major area of our life where there is often a struggle over who will control it - self or the Lord Jesus Christ. For each of these areas ask the question, "Is Jesus Christ Lord?" Are you truly seeking God's will or are you just asking God to rubber-stamp your plans? Note the blank spaces in the illustration. This is for you to fill in areas not listed - areas that may be a special battle zone for you in this issue of Lordship. It could be the area of appearance or clothes or food and drink!

# LEADERSHIP

“Leadership consists in the ability to lead others. It requires personal qualities that inspire others with absolute confidence and respect. It is compounded of character, prestige, knowledge, experience, independent initiative, tenacity, force and physical and moral courage.

It involves setting an example to, and looking after the welfare of others, cheerfully sharing their dangers and hardships with them, and the ability and willingness to do anything, however difficult or hazards, that others are asked to do.” Army Officers Manual, 1941.

## QUOTES

“Leadership involves lifting others up to their full potential in Christ. It requires vision, availability, a servant-heart, and the growing edge of love for Christ and the lost world.”

“We don’t plan to fail, we fail to plan. If you don’t know where you’re going, any road will get you there.” Anon.

“The great paralysis of the heart is unbelief. Immediately I view anything as inevitable about any human being, I am an unbeliever.” Oswald Chambers

“Deepen your message. Let God broaden your ministry.” Bill Gothard

“God wants us to make good. He lovingly seeks to guide us. Anything you give to the Lord, He will multiply it 5, 20, 100, 1,000 times.” Roy Robertson

“What are you giving in exchange for your life? You are giving yourself up for something else in exchange for your life.” Roy Robertson

“You are meant to incarnate in your lives the theme of your Adoration. You are to be taken consecrated, broken, broken and distributed, that you may be the means of grace and vehicles of the Eternal Charity.” Augustine

“We are all in the same boat in a stormy sea. And we owe each other a terrible loyalty.” G.K. Chesterton

“It is the fine art of the Holy Spirit to be alone with God.” Oswald Chambers

“The true nature of anything is in what it can become.” Aristotle

“A lover IS a leader.” Howard Hendricks

“The greatest test of faith is trusting God for people.” Dawson Trotman

“Leadership should dominate change, rather than react to it.” Anon

“Beware of the people who tell you life is simple. Life is such a mass of complications that no man is safe apart from God. Coming to Jesus does not simplify life, it simplifies my relationship to God.” Oswald Chambers

“The one mark of discipleship is the mastership of Jesus – His right to me from the crown of my head to the sole of my feet.” Oswald Chambers

# A DISCIPLE IS A LEARNER

A Disciple Is A Learner - Open and Teachable. Matt. 11:29; Eph. 4:20,21; II Tim. 3:14. The secular use of the word disciple carries with it the idea of apprenticeship. An apprentice is one who was bound by a covenant to a master craftsman for a certain period of time with the view to learn his craft, mystery, or occupation, in which his master is also bound to instruct him. Apprenticeship is the term for which an apprentice was obligated under oath and covenant to his master to serve his master. In 1828 in England the term was seven years by law. At the same time in Paris the term was five years. It was necessary to serve first as an apprentice for five years and then as a journeyman for five years in order to become a master. While serving the time as a journeyman the apprentice was called the companion of his master and the term was called his companionship. Luke 6:40

When fully discipled the followers of Christ were to be like Him in spite of their diverse and unique individuality. They were to retain the distinct characteristics of their own personalities.

A disciple is truly a follower of the Lord Jesus Christ, desiring to learn His ways and apply them to his life. This means that a disciple has to be open and teachable. He is a follower who desires to learn.

Being a learner involves perceiving concepts, building principles in our life, and acquiring knowledge. Skills are to be learned and developed as well in activities such as evangelism, leading Bible studies, or teaching Sunday School classes.

As followers, what we learn may be more caught than taught. Positive and attractive or desirable things may be seen in the life of another and then built into our own lives.

Paul not only communicated what he taught by word but he modeled it as well.

Phil. 4:9; I Thess. 1:6,7; I Cor. 11:1; I Cor. 4:15,16; II Tim. 3:10,11.

The Christian disciple must be both a learner of Biblical truths and a visible follower of Jesus Christ.

## AREAS IN WHICH TO DEVELOP

### I. Character.

Character forms the inner person out of which flows the real person who is visible to the world. Character qualities are basically those Christlike qualities that are the fruit of the Spirit living in us: "love, joy, peace, long-suffering (patience), gentleness (kindness), goodness, faith, meekness, temperance (self-control)." Gal. 5:22,23. These qualities are what people will remember us by.

A. Love. Rom. 5:5; II Cor. 5:14,15; I Cor. 13:4-8a.

B. Joy. Joy of the Lord and joy in the Lord. John 15:11; I John 1:4; I Peter 1:8.

C. Peace. Peace of God and peace with God. Rom. 5:1; Eph. 2:14; Phil. 4:7; John 14:27; Col. 3:15.

People need to see the peace of God in us - the fact that nothing seems to destroy the tranquility of our relationship with the Lord.

D. Longsuffering. The patience in which we bear the pressures of life as God would have us. Eph. 4:1,2; Col. 1:11; Col. 3:12,13.

1. Patience can only be developed by diverse trials in our lives. Rom. 5:3-5, James 1:3,4.
  2. If our sufficiency is in ourselves, we will be caught in a vicious circle of repetition until the Lord becomes our sufficiency.
  3. We are commanded to be patient. Rom. 12:12; I Thess. 5:14; James 5:7,8; Heb. 10:36; I Tim. 6:11.
  4. It helps to recognize that we are not the only ones to be tried and have needs. James 5:10,11; II Cor. 6:4-10; II Cor. 12:12; Heb. 6:12,15.
  5. Our Lord walked the road of patience before us. Heb. 12:1-3.
  6. Additional passages on patience to consider. II Pet. 1:5-8.
- E. Gentleness. Kindness demonstrated toward others is not a natural trait of the flesh. If this is practiced, our inner character thus will stand out for all to see. Ps. 18:35.
- F. Goodness. Eph. 5:9.
- G. Faith. People should seek our faith, which is our confidence in God's trustworthiness and promises. Rom. 12:3; Eph. 4:5; Acts 6:5,8; 11:24; II Cor. 4:13; Heb. 11:9.
- H. Meekness. Our recognition that God alone is our defense and capable of handling any mistreatment by others. Rom. 4:20,21.
- I. Temperance. Self control - not under the control of self or any other thing. II Pet. 1:6; I Cor. 9:25, 6:12.
1. Control over appetite. Prov. 23:2,3.
  2. Control over anger. Eccl. 7:9; Prov. 16:32; 19:11.
  3. Control over flesh. Col. 3:5, 8-10.
  4. Control over eyes. Matt. 6:22,23; I John 2:16,17.
  5. Control over covetousness. Prov. 28:16; Eph. 5:3; Col. 3:5.
  6. Control over tongue. Ps. 34:13; 39:1; 52:2-4; Prov. 16:1; 21:23; James 1:26; 3:5-8; I Pet. 3:10.

We must take personal responsibility for character development that is Christ-like. II Tim. 2:20,21; Eccl. 10:1.

"Slightly soiled, greatly reduced in price!" was used originally in department store sales of damaged clothing. Now it is a tag stuck to some men with character flaws. This does not honor the Lord in the life of a Christian.

The disciple as a learner and follower must have a commitment to develop his character so it will reflect the Lord Jesus Christ.

## II. Proficiency In Ministry.

The quality of a person's character will be reflected in their ministry. If a person is mature in character, he will have an effective ministry; if he is immature or there are weaknesses in his character, his ministry will be shallow and superficial.

- A. The key to proficiency is commitment to excellence. Mark 7:37a.
1. God has given certain gifts to every Christian. Rom 12:3,6a; Eph.4:7.
  2. Our ministry skills must be developed fully. I Tim. 4:15; I Cor. 10:31; Col. 3:23.
  3. If we concentrate on quality, it will eventually produce quantity.

- B. "We fall into the error of thinking that happiness necessarily involves ease, diversion, tranquility, a state in which all of one's wishes are satisfied. For most people, happiness is not to be found in this vegetative state but in striving toward meaningful goals". John W. Gardner, *Excellence Can Be Equal and Excellent Too!*
- C. Development of proficiency in ministry is a must for a disciple of Jesus Christ.

### III. Conviction.

Disciples must be brought to the place where they base what they believe on their own convictions. It is dangerous to base convictions only on someone else's convictions. If we have convictions about becoming disciples and making disciples, then we will both be and make disciples. If we do not have convictions in this area, then we will neither be nor make disciples.

The Lord did not give all the details about how the Great Commission was to be carried out. He simply told us to do it. Because He told us to do it, we should have strong convictions about its importance and develop effective methods. If a person has convictions, he will find the necessary methods to apply them. On the other hand, give a person all the methodology available, but if he does not have convictions, he will not use the methods - or will half-heartily use them and there will be no results.

- A. Convictions demand decisions.
  1. Moses. Heb. 11:24,25.
  2. Joshua. Joshua 24:15.
  3. Abraham. Gen. 18:19.

### IV. Perspective.

- A. Perspective is the ability to see the probable end as well as the beginning. Some call it bi-focal vision; the ability to see what is directly in front of you as well as what is down the road in the distance.  
Perspective is a rare commodity in our day among Christians. We only seem to be able to see the now, the immediate. We are not able to see what the long-range results of our actions might be.
- B. Perspective is also an ability to see things of life from God's point of view. Isaiah 55:8,9.
- C. Perspective includes a positive view of our immediate circumstances. Circumstances can be seen as hindrances or as stepping stones. You can view them as defeats or delightful opportunities.

### V. How Can Conviction and Perspective Be Built Into Our Life?

- A. Major on principles rather than methods.
  1. Principles are universal.
  2. Principles will work anywhere.
  3. Principles will work anytime.
  4. Methods are not absolute.
  5. Methods may vary from time to time and from place to place.

6. The person with conviction and perspective uses whatever methods are necessary and available and gets the job done.
- B. Focus on the "why" of what you are doing.
1. Emphasize the purpose rather than the skills.
  2. Purpose will develop the skills.
  3. When we know why we are doing something, then it is easier to do what we are supposed to do.
- C. Concentrate on trusting God rather than learning theories about Him.
1. It is more important to have a dynamic personal relationship with God than to know and understand every theological detail.
    - a. Enoch. Gen. 5:22,24.
    - b. Moses.
    - c. David. I Sam 13:14; Acts 13:22.
  2. A disciple has to learn how to trust God totally.
  3. The principle of faith must control, dominate, and permeate every area of our lives. Hab. 2:4; Rom. 1:17; Gal. 3:11; Heb. 10:38; II Cor. 5:7.
  4. It is this firm trust in God that will develop convictions by experience. Rom. 4:20,21.

# PURITY OF LIFE

A disciple is committed to a life of purity and is taking steps to separate from sin. - II Cor. 5:17; I John 3:9; Rom. 6:13; I Cor. 6:18-20; II Cor. 6:17.

## I. Repentance.

Luke 13:3; Acts 2:38; 17:30; 26:30; II Peter 3:9.

Repentance means a change of mind. This involves a change of mind toward sin, toward self and toward God. Repentance is also agreement with God. Again this is agreement with God about sin, about self and about God Himself.

- A. Repentance is not sorrow.
- B. Sorrow which is due to a wounded ego is not repentance.
- C. Sorrow brought on by discovery of sin is not repentance.
- D. Sorrow which results from a judgment of sin is not repentance.

*A repentant sinner is sorry that he has offended a holy God and is determined to change. True repentance and conversion or faith always go together. We repent of our sins and turn to God.*

## II. Evidence Of Repentance.

A Christian should show evidence of repentance in his or her life.

- A. A change of attitudes.
  - 1. Change of attitude toward God.
  - 2. Change of attitude toward sin.
  - 3. Change of attitude toward self.
  - 4. Change of attitude about salvation.
  - 5. Change of attitude about daily issues of life.
- B. A Change of Desires. II Cor. 5:17.
  - 1. Instead of living for self, one will be concerned about living for God.
  - 2. Instead of desires for possessions, fame or popularity, focus will be on the person of Christ.
  - 3. A believer loves what he once hated and hates what he once loved.
- C. An Abhorrence of Sin.
  - 1. One who has truly repented understands how sin appears to God and consciously and deliberately turn away from it.
  - 2. A deep sensitivity to sin in our life comes as a result of the Holy Spirit's taking up residence in us. Prov. 8:13.
  - 3. A saved person commits themselves to being governed by the Bible's absolutes.
- D. Breaking Off Old Influences. I Cor. 15:33; Prov. 22:24,25; Gal. 5:7-10; II Peter 2:18; Duet. 13:6; Prov. 1:10; 28:10.
  - 1. Old friends can exert much pressure and may be a detriment and "snare" to new Christians.
  - 2. As one grows in Christ, it is nothing but natural that their circle of friends includes more Christians.
  - 3. God does not want us usually to sever all non-Christian relationships but He wants us to sever everything that would draw us back into sin.



4. The Gospel needs to be ministered to old friends but it is not possible for the Christian to participate in the sinful activities.

### **III. God's Standards For Purity Of Life. Matt. 5:8; Prov. 4:23; 6:18.**

- A. Purity of life begins in the heart.
- B. God knows our heart. I John 3:20.
- C. Our nature is to constantly attempt to disguise our heart's condition.
- D. The Spirit of God will reveal the sin in our hearts. I John 3:21.
- E. If we are having problems with lustful thoughts, we can consciously and deliberately abstain from them. I Peter 2:11,12.
- F. It is possible to be in the presence of God with a pure heart. Ps. 24:3,4.

### **IV. Conflict Between The Flesh And The Spirit.**

- A. The unbeliever is governed by the flesh, the Adamic nature. I Cor. 2:14.
- B. When a sinner trusts Christ, he receives a new nature. I Cor. 2:12.
- C. The flesh and the Spirit are constantly battling for control. Gal. 5:17,18; Rom. 7:23.
- D. There must be a complete and total dedication of self - body, soul and spirit to the Lord. Rom. 12:1,2; 6:16.
- E. The nature that we feed is the nature that will control us. Matt. 4:4; Rom. 8:13,14.

### **V. The Battle For Purity.**

There is always present the potential for a believer to fall. There are also God-provided means for victory.

- A. Promises of the Word of God. I Cor. 10:13; Titus 2:11-14.
- B. The help of the Holy Spirit.
  1. At the moment of salvation the believer receives the indwelling presence of the Holy Spirit. Gal. 3:2; I John 4:13.
  2. The Holy Spirit will minister to us. Rom. 8:26.
- C. The intercession of Christ. Rom. 8:34; Heb. 7:25.
- D. The prayers of other Christians. Phil. 1:3-10; Eph. 1:15,16; I Tim. 2:1; James 5:16.
- E. The fellowship of other believers and a good church. Heb. 10:24,25; I Cor. 12:25,26.
- F. Faith. I John 5:4.
- G. Yielding or dedication of every part of us to the Lordship of Christ. Rom. 6:13.

### **VI. Areas Of Purity Of Life.**

Many passages of Scripture reveal the standards for purity that God expects of His people.

- A. We are to be pure in Spirit. II Cor. 7:1.
  1. Impure things that we think about contaminate our spirit.
  2. Impurity originates inside us - in the heart. Mark 7:20-23.
  3. Our heart and mind is to be filled with the Word of God. Phil. 4:8; Ps. 119:11.
- B. We are to be pure in our thoughts.
  1. Our thoughts must be brought under the control of Christ, if there is to be victory. II Cor. 10:4,5.

2. The relationship between a thought and an act is expressed in the following poem.  
Sow a thought, reap a word;  
Sow a word, reap an act;  
Sow an act, reap a habit;  
Sow a habit, reap destiny
  3. Covenants need to be made with ourselves. Job. 31:1.
- C. We are to be pure in speech.
1. Questionable conversation and questionable jobs must be put aside. Eph. 4:29,31; 5:4; James 3:6; 4:11; 1 Peter 2:1.
  2. Our speech is to be for the edifying of others and for the glorifying of the Lord. Col. 3:16,17; Eph. 5:19.
- D. We are to be pure in our dealings with others. Matt. 7:12; Eph. 4:25-28, 31-32; Matt. 5:16.
- E. We are to be pure in our business dealings. James 4:1; Deut. 16:20; Ps. 82:3; Prov. 21:3; Rom. 13:7.
- F. We are to be pure in personal relationships.
1. Family. Eph. 5:22-33.
  2. Marriage. I Cor. 13:4-8a.
  3. Friends. Prov. 18:24; 27:17.

# A DISCIPLE IS A SERVANT

A disciple demonstrates a servant heart by helping others in practical ways. Matt. 20:25-28; I John 3:16; Matt. 23:11.

## I. What Is A Servant?

- A. The term servant in the Scriptures is used in a variety of ways.
  1. Many times servants were called slaves. Deut. 5:15.
    - a. Some were bought. Ex. 21:2; Ps. 105:17.
    - b. Some were taken in wars. I Sam. 17:9.
    - c. Some were slaves because of debts. II Kings 4:1.
  2. In the Old Testament entire nations were required to serve their King or those who conquered them. I Kings 1:9; 12:7.
  3. The person who dedicates himself to the service of another by his own choice of will is also considered a servant. Deut. 15:16,17; II Cor. 4:5; I Cor. 9:19; Rom. 1:1.
  4. The most common reference in the Scriptures is to servants of the Lord.
    - a. They are the faithful and dedicated persons who have been redeemed from sin and are now serving God in righteousness and holiness. Rom. 6:17,18.
    - b. A person who serves God in a particular function or calling is designated a Servant of God. Example: The Lord Jesus Christ. Is. 53:11.
    - c. The expression "Servant of God" is applied at times to a person whom God uses to perform His will in a particular way or is used for a special purpose.
      - (1.) Moses is called the Servant of God seventeen times. Josh. 1:2
      - (2.) David is called the Servant of God twenty-four times. II Sam. 7:5.

*To summarize, a servant is a person who does not exercise his own will but rather submits it in order to please his master. He also demonstrates the importance of serving another without any assurance of reward.*

## II. Biblical Characteristics Found In A Servant.

- A. A servant is humble.
  1. He does not attract attention to himself.
  2. He stays in the background and does his work.
  3. The servant is to "gently instruct" those who oppose him. II Tim. 2:25.
- B. A servant is diligent. Matt. 24:45-47.
  1. He is active in doing his work.
  2. He is not slothful.
- C. A servant is busy serving. Luke 17:7,8.
- D. A servant should be able to teach. II Tim. 2:24.
  1. A servant trains others to serve.
  2. This may entail years of apprenticeship in behalf of those who are learning.
- E. A servant is patient. II Tim. 2:24.
  1. The opposite of patience is being resentful with the circumstances that keep us from doing what we think ought to be done.
  2. One of the results of impatience is discouragement.

3. A servant should do his work and not become discouraged when things do not go his way.
  4. The same is true when we as disciples spend time and work with others.
- F. A servant is gentle. II Tim. 2:25.
1. Roughness and rowdiness does not serve people, neither will it produce repentance.
  2. Here Paul instructed Timothy to be gentle with those of the opposition whom he would be instructing in things of God.
- G. A servant is obedient. Eph. 6:5,6.
1. Here is the heart of servanthood and the reason so many have problems with it.
  2. One of the responsibilities of Christian leadership is to teach servants of the Lord to serve in submission, pleasing those over them, without talking back. Titus 2:9.
- H. A servant is dedicated. II Sam. 15:21.
1. When a servant commits himself to whom he serves, he does it with the totality of his heart.
  2. Ittai, a servant of David, is a beautiful example of dedication when David was overthrown in a palace coup and had to flee for his life.
- I. A servant is watchful. Luke 12:35,36.
1. A servant is alert to the needs his master might have and to the work that needs doing.
  2. A servant is prepared to respond immediately - not encumbered doing what he wants to do.
- J. A servant is faithful. I Sam. 22:14.
1. Even when Saul was attempting to take David's life, he remained loyal to King Saul.
  2. No matter what happens, a servant remains faithful to his master.
- K. A servant is not contentious. Titus 2:9.
1. A servant respects his master and does not talk back to him under any circumstances.
  2. Harmony in the household enables the servant to do that which he is supposed to do - serve.
- L. Servant is Spirit-filled. Acts 2:16,18.
1. The power and filling of the Holy Spirit of God are necessary for real servanthood.
  2. The enabling power for Christian servanthood comes from the Holy Spirit.

### III. Servanthood And Discipleship.

- A. The Scriptures call on all of us who would be disciples of the Lord Jesus Christ to be His servants both by precept and example.
- B. When we act like servants, it is obvious to all. John 13:34,35.
- C. Servanthood is intensely practical and works in everyday life.
- D. Many people have doctrine well learned but are unfamiliar with the terms and techniques of serving.
- E. There are those that do Bible study and memorize Scripture but are not willing to spend time serving.

- F. The servants are few while the needs and opportunities are many and great - one of the greatest weaknesses in Christendom today.

#### **IV. How We Can Be Servants.**

- A. Be willing to do menial tasks. Luke 16:10; Matt. 25:21,45.
  - 1. Pride makes us think that because of status, accomplishments, educational attainments, age or position we are “above” or “exempt” from menial tasks.
  - 2. Incorrect thinking has caused us to focus on our so-called “rights” rather than the true facts of life.
- B. Be available. Luke 9:59-62.
  - 1. One of the characteristics of servants in a household is that they must be available when they are called.
  - 2. The Christian servant must also be available - to the Lord and to those it is his ministry to serve.
- C. Be observant. Ps. 123:2.
  - 1. The needs of guests in a Hebrew household were communicated to the servants by hand signals, so it was the responsibility of those serving to watch the hands of the master and mistress.
  - 2. A servant must be alert to the needs of others.
- D. Do more than you are asked to do.
  - 1. In our society today, people do just what they are asked to do, nothing more.
    - a. If they are asked to do a little more than their job description calls for they want overtime or other compensation or they just flat refuse to do it.
    - b. Consequently, people do as little as they can when for the good of all it should be the opposite.

#### **V. The Results Of Being A True Servant.**

What happens in a person’s life when he manifests the characteristics of servanthood?

- A. The servant who is faithful in all his responsibilities will be recognized by his master. Matt. 25:21.
- B. Honor from God will come to the faithful servant of the Lord. John 12:26.
- C. The servant may be served by his own Master. Luke 12:37,38.

# ESTABLISHING A DISCIPLE IN A FELLOWSHIP OF BELIEVERS

The importance of Bible knowledge must be balanced with love from a body of believers. A new believer must receive love and attention from other believers.

## I. The Example of Paul.

- A. Paul understood the importance of loving people.
  - 1. Love in word. I Cor. 13:1.
  - 2. Love, knowledge and faith must be balanced. I Cor. 13:2.
  - 3. Love is more important than sacrifice. I Cor. 13:3
- B. Paul loved new believers. I Thess. 2:7-9.
  - 1. Paul had a great sense of responsibility toward new believers.
  - 2. Three things Paul did.
    - a. "We were gentle among you." I Thess. 2:7.
    - b. "We were willing to ...impart the Gospel." I Thess. 2:8.
    - c. "We were willing to impart ...our own souls." I Thess. 2:8b
- C. Note how Paul was gentle.
  - 1. He took on the role of a nurse.
  - 2. Because they were babes in Christ.
    - a. Babies need a lot of attention.
    - b. Babies need a lot of milk.
    - c. Babies need a lot of changing.
    - d. Babies need a lot of correction.
  - 3. "Being affectionately desirous" will lead one to give continuous care.
- D. Paul imparted to them the Gospel.
  - 1. Not just the death, burial and resurrection of Christ.
  - 2. Everything that entailed:
    - a. Identification with Christ.
    - b. Justification.
    - c. Sanctification.
    - d. Glorification.
- E. Paul imparted to them his soul.
  - 1. For Paul, love was spelled "commitment".
  - 2. Everything Paul had was theirs.

## II. Two Rolls In Discipleship. I Cor. 4:14-17.

- A. The role of a father.
  - 1. Defined: One who has borne sons in the faith.
    - a. "My beloved sons, I warn you." I Cor. 4:14b.
    - b. "I have begotten you through the Gospel. I Cor. 4:15b.
  - 2. A fathers responsibility.
    - a. "Be ye followers of me." I Cor. 4:16b.
    - b. To provide proper instructors. I Cor. 4:17a.
    - c. To provide proper instruction. I Cor. 4:17b.

- B. The role of an instructor.
  - 1. Defined: One who is qualified and authorized to teach others the Word of God.
  - 2. He is one who teaches believers whom he did not personally reach for Christ.
  - 3. Prerequisite: Must be "faithful". I Cor. 4:1,2.

### **III. True Fellowship Is Sharing The Live Of Christ With Each Other.**

- A. Fellowship: To communicate with partnership.
- B. No true fellowship without commitment.
- C. Are you willing to commit your life to true fellowship?

# WHAT IS THE KEY TO WORLDWIDE EVANGELIZATION?

The answer is a simple one - missions. But is it that simple? Some of the fields that missionaries are going to were once the very centers of evangelism. What happened we ask ourselves to these centers of evangelism? Did persecution destroy the efforts of these centers? Or was it God's will that they cease to evangelize the world? History tells us that when the Church came under persecution they thrived with fervent zeal in evangelism. We know that God has never put a red light on evangelism. So what was the cause of the slackness in Worldwide Evangelism? I believe the answer lies within the Great Commission.

We find in the commission in Matt. 28:18-20 the secret to Worldwide Evangelism. This commission was given to the disciples who formed the local church during our Lord's Ministry. We find here four parts to the Commission.

- I. **MISSIONS - Personal Responsibility Of The Propagation Of The Gospel - "Go Ye."**  
We are given all power to go.
- II. **MESSAGE - Personal Revelation Of The Person Of The Gospel - "Teach All Nations."**  
We are given all nations to teach.
- III. **MANIFESTATION - Personal Identification Of The Believer With The Gospel - "Baptizing Them In The Name Of The Father, And The Son, And Of The Holy Ghost."**  
We are given all believers to baptize.
- IV. **METHOD - Personal Discipleship Of The Believer In The Gospel - "Teaching Them To Observe All Things whatsoever I Have Commanded You."**  
We are given all things to train.

If you accomplish the first three and not the last, your efforts of Evangelization of the world will be a failure. We must produce Disciples that Evangelize to provide a continued ministry in any area. The early history of the Church in Acts reveals that the Christians were willing not only to give their lives but also their lands. Those were disciples that had dedication and devotion to the Lord. What an impact it had on the World in that day. Thousands came to know Christ and local churches sprung up everywhere. There was a great multiplication of fruit which continued until the **WHOLE WORLD HEARD THE MESSAGE IN THAT DAY.**

If we go back to the Gospel accounts and search them, we'll find the interwoven principle that the Lord was going to use to change a world. He had a strategy that if adopted will again make a Worldwide impact of a magnitude that could be compared with the Early Church. If we in our day are going to accomplish this monumental task of Worldwide Evangelization, we need to return to the strategy of Our Lord - Discipleship. Our Lord had a Plan, a Purpose and a Pattern and He never lost sight of these Eternal objectives. Every word He spoke, every work he performed and every walk he made was a part of the objective. There was no haphazardness,



wasted energy or idle words in His life. Every thing counted. Time was important and the right moment was of necessity. He was Decisive, Devoted and Determined in every action.

He organized and predetermined His objectives before He ever left Glory. His objectives were clear.

**I. He Had A Foreordained Plan In Reconciliation**

The Cross - Salvation

**II. He Had A Fulfilling Purpose In Redemption.**

The Church - Separation.

**III. He Had A Final Pattern In Reproducing Regenerated Souls.**

The Commission - Service.

We are not in the reforming business, we are in the transforming business.

Yes, men are His METHOD, The Holy Spirit, HIS POWER, the Word of God His VOICE and the BLOOD STAINED CROSS THE WAY OF EVANGELIZATION. He transformed the world by the men He had transformed through His WORK, WALK and WORDS. The disciples were molded men in the hands of the Eternal Potter. The Lord has given to us the GREAT RESPONSIBILITY – EVANGELIZE THE WORLD. He has given us the MODEL METHOD – DISCIPLESHIP. What He did with the few was for the Evangelization and Salvation of the MULTITUDES. Without His DIVINE PLAN our energies will be wasted. Without His DIVINE PURPOSE, our efforts will be but failures. Without His DECISIVE PATTERN our involvement will be slack. We must determine to make a TOTAL COMMITMENT to His METHOD. We must be OBEDIENT and LOYAL to His OBJECTIVES. We must surrender our all to Him in ABSOLUTE SUBMISSION to His SOVEREIGNTY. We ought to COUNT THE COST OF DISOBEDIENCE and pay the price of DEDICATION - DISCIPLESHIP.

Discipleship is not an alternative, it is the ultimate objective. We must disciple if we are going to evangelize. We must decide if we want our efforts to count in the temporal applause of members or in the ETERNAL BENEFITS of a reproductive ministry. In order for those we have led to Christ to fulfill the Commission, they must go from LEARNERS TO LEADERS and the only way to accomplish this is DISCIPLESHIP. The emphasis today is upon members, membership, baptisms with little or no concern to Disciple in the Power, Plan, Purpose and Pattern of our Lord. If we were to begin to count those that are in our ministry that are doing something for the Lord, we would have a better perspective of our ministry. Eternal Destinies are at stake.

We need to realize that we are engaged in a WAR, the issues of which are Heaven or Hell, Life or Death, and not be indifferent to our responsibility to Discipleship. There is no place for a Church or individuals that are slackers in this war. We must have knowledge to be affective in our efforts, power to be efficient in our work and prayer to be right in our motives. Those that have been disciplined will have these. Let us arise with renewed zeal, holding forth the Word of Life and lifting high the banner of the Cross through men DISCIPLED IN LOVE, DISCIPLINED IN LIFE and DEVOTED IN DOCTRINE to the Lord. The call comes to abandon self, bear the Cross and follow as Disciples. We need men that are Discipled with a World-wide Vision controlled with compassion, conviction and no compromise. The price we are paying today is determining the future of Evangelization tomorrow. We have the obligation as well as the

privilege to change the course of Evangelization. What will be our decision? What will be our Lord's verdict? What will be men's Destiny? If we don't take action now we will lose the advantages of tomorrow.

If we have disciplined converts, we will have devoted Christians.

# WHY PEOPLE ATTEND THE CHURCH THEY DO

(Institute for American Church Growth)

Questionnaire: 10,000 lay people

Special Need	2%
Walk - in	3%
Pastor	6%
Visitation	1%
Sunday School	5%
Evangelistic Crusade	½%
Programs	3%
Friend/Relative	79%

# CHARACTERISTICS THAT MUST BE IN OUR LIFE IF WE ARE TO DISCIPLE OTHERS

I Thess. 2:8

Personal follow-up is much more than merely imparting information - it is the imparting of your very life.

## I. Be Open And Involved.

- A. View a new Christian from God's perspective. II Cor. 5:17
  - 1. Their potential must be considered - not their failures or weaknesses.
  - 2. God can use and develop anyone into an effective instrument to be used by Him.
- B. Be honest and not put up a front. Phil. 3:12
  - 1. Many are hindered in proper discipling because they feel they have to appear as a "spiritual giant".
  - 2. Be human and admit you do not have all the answers.

## II. Believe In The Importance Of Personal Follow-Up.

- A. Personal discipling will only be done by those who are convinced of its importance.
- B. Personal discipling will only be done by those willing to spend the time it involves.
- C. Personal discipling will only be done by those who recognize proper priorities.
- D. Follow-through to maturity will not be endured unless discipleship is viewed as a major priority in our life.

## III. Desire To Be Used. Matt. 5:6.

- A. How can one demonstrate the desire to be used.
  - 1. Tell the Lord in prayer.
  - 2. Be a doer of the Word and not merely a hearer. James 1:22.
  - 3. Demonstrate practically that desire by acquiring proper training.
  - 4. Be consistent in outreach.
- B. Get to where the action is.
  - 1. It is not enough just to talk about it.
  - 2. Serve the Lord now.

## IV. Being Available.

- A. No matter how skilled or effective one may be, if he is unavailable God cannot use him.
  - 1. A classical example is Jeremiah. Jerm. 1:4-10.
    - a. Jeremiah rationalized that he was too young, untrained, and not a good speaker.
    - b. They were only excuses that were a cover for his unavailability.
  - 2. Another example is God's call to Moses. Ex. 3:7-4:1,10,13.
    - a. Moses' first excuse was that he was just average. Ex. 3:11.

- b. His next excuse was one of credibility. Ex. 4:1
  - c. Moses then presented his natural limitations as an excuse. Ex. 4:10.
  - d. Moses was unavailable and asked God to send someone else. Ex. 4:13.
- B. Lack of availability may be the only limitation preventing your effectiveness in discipling.

## V. Consistency Of Life.

- A. An inconsistent walk with the Lord cannot be hidden.
- B. Demonstration or modeling plays a large role in developing people.
- C. Like produces like.
  - 1. The question is not if you will reproduce, but what will you reproduce.
  - 2. Paul placed much importance on example - his own and the example of others. I Tim 4:11,12.
  - 3. Luke 6:40 cannot be denied.

## VI. Growing In Christ.

- A. As long as we have life we must continue to grow.
- B. We are commanded to grow. II Pet. 3:18.
- C. We must not assume that we have "arrived".
- D. Paul again left us a good attitude to adopt in seeking to understand God's will regarding growth. Phil. 3:12-14.

## VII. Accept Yourself.

- A. A person's attitude toward himself has a marked effect upon his follow-up effectiveness.
  - 1. One who has not come to a personal self-acceptance will be limited in his ability to work effectively with other people.
  - 2. If you have been unable to accept yourself, you will unconsciously be afraid others won't accept you either.
  - 3. This unconscious fear tends to prevent you from being open and honest with people.
    - a. This fear will cause us to build false fronts in our lives that make us appear more acceptable to others.
    - b. When this happens, the transparency of life, so important to effective relationships with other people, is destroyed.
- B. God in His sovereignty made us and has a perfect plan for us in making us the way He did.
  - 1. Lack of self-acceptance indicates an unwillingness to accept ourselves as God created us.
    - a. This means we have never accepted our physical appearance and abilities (or lack of them), our mental limitations, and the unchangeable aspects of our environment, economic, physical, etc.
    - b. Rebellion against the parents God gave us is related here.
  - 2. These attitudes, and others related, reveal our resentment toward God. Rom. 8:28, Phil. 4:11; I Thess. 5:18.

3. Until we accept the fact that God had a perfect plan in making us the way He did, we will never be effective in follow-up.
  - a. We are not talking about accepting the sin in your life.
  - b. We are not talking about being content with sinful problems.
  - c. Examples: You were born with freckles and red hair but was not born with a temper to be tolerated.

Maybe you were born into a rich family, but you were not born to be lazy.
4. God wants us to trust Him and His wisdom in the midst of unchangeable circumstances.

My prayer is that this list of attitudes and actions which affect your being useful and effective in other lives will stimulate your thinking and motivate you to prepare for effective discipleship.

# CRITERIA FOR FAITHFUL MEN

What do we look for in a Potential Timothy?

**I. Saved Person.**

No need to discuss

**II. Person God Chooses.**

I Sam. 16:6,7; II Chron. 16:9; Ps. 53:2.

**III. Hunger For Word - Heart For God.**

Matt. 5:6; Ps. 42:1; 63:1; Deut. 5:29.

**IV. Teachable Attitude**

I Thess. 5:21.

**V. Obedient.**

John 7:17; 15:10; I John 2:3-5; 3:24.

**VI. Availability**

- A. Isaiah was available - Isa. 6:8.
- B. Elisha - II King 2:2
- C. The armor bearer of Jonathan - I Sam. 14:6,7.

**VII. Faithfulness.**

Dan. 6:3,4; Neh. 9:7,8a; Luke 16:10; Prov. 25:19.

- A. Finding faithful men is difficult - Luke 18:8; Prov. 20:6.
- B. Faithfulness equals fruitfulness - Matt. 25:14-30.
- C. There is joy in finding faithful men - Prov. 25:13; III John 4.

## A PARENT HEART

**I. A Parent Loves His Children - John 13:35; Acts 20:20,32; I Thess. 2:8; II Cor. 12:15; I John 3:16. "Not making converts to our ways of thinking but making disciples of Jesus."**

**II. A Parent Feeds His Children - Acts 20:20,27; John 21:15-17.**

A. Feed him by teaching the need of a personal time with the Lord - Dan. 6:10-11.

1. A definite place - Mat. 6:6.
2. A definite time - Mark 1:35.
3. A definite content - a plan - prepare.

B. Feed him by impressing upon him the need to take sermon notes. We forget 90% of what we hear. Taking sermon notes cuts the percentage loss by at least half. The members of the congregation are as responsible to leave with the sermon as the preacher is to bring it.

C. Feed him by teaching him how to read the Bible. We remember only a little more of what we read than what we hear. So, again, it is imperative to take notes to improve our retention.

Some things to look for and jot down.

1. Main lesson.
2. Verse which summarizes passage.
3. Command to obey.
4. What God is teaching me right now from this passage.

D. Feed him by teaching Bible study methods. The disciple must learn to "eat the Word" for himself.

E. Feed him by teaching scripture memory - Ps. 119:11; 1:2,3; Prov. 2:1; 3:1,3.

**III. A Parent Protects His Children - Luke 22:31,32.**

A. Protection from temptation - I John 2:15,16.

Three basic temptations used by Satan - I John 2:15,16.

1. Lust of the eye. Lust begins with a look - Prov. 4:25-27; 4:23; 27:20; Ecc. 1:8; Matt. 5:29.
2. Lust of the flesh. Money and possessions can be a problem to a young Christian. Do you have your money under control or does money have you under control - I Tim. 6:9,10; Matt. 6:24; 6:19,20; I Tim. 6:8.
3. Pride of life. "Say little, serve all, pass on." Remember, the Lord is the rewarder of them that diligently seek Him. He Himself is our ultimate reward - Gen. 15:1, Phil. 2:3-5. May God help us with the excessive desire for self-recognition.

B. Protection through discipline - Heb. 3:13; 12:5-13; Ecc. 8:11. "Little seeds produce big trees which block the sunlight of God's purposes." "As the twig is bent, so grows a tree." Prov. 28:23. Loving confrontation: charge, admonish, rebuke, reprove, correct, exhort, comfort.

1. How to admonish in love.



- a. The Word of God is always the basis for admonition. It is imperative that we know and are sure that the offense is clearly contrary to scripture - Titus 2:1; Matt. 18:6.
- b. Use discretion. Timing is essential. Sometimes it is God's plan for us to apply this truth - Prov. 19:11.
- c. The discipler must fulfill the requirements of Gal. 6:1. We must be controlled by the Holy Spirit.
- d. We are not called to confront everyone we meet who has a sin problem. Winning the heart is a key to a positive response, but it takes time. Also, we are not everyone's spiritual parents, neither has the Lord accorded us the authority to confront them.
- e. The admonition must be reasonable, given in a loving manner, as from a brother, and it should convey compassion and tenderness - II Cor. 2:4.
- f. Admonishing another must be done in meekness - Gal. 6:1. Remember, this same thing could happen to you. Speak carefully and with a humble heart.
- g. Do it privately - Prov. 25:9; Matt. 18:15.
- h. Do it with perseverance. Don't allow yourself to get weary and discouraged. Afterwards be finished with it - Prov. 13:19; 28:23.

**IV. A Parent Trains His Children - I Cor. 4:15.**

- A. Tell him why.
- B. Show him how.
- C. Get him started.
- D. Keep him going.

## QUOTES TO REMEMBER

"If you want your own way, God will let you have it. Hell is the enjoyment of one's own way forever." Dorothy Sayers

"God is as committed to you as He is to Jesus; and will do for you what He did for Jesus." Joe Boatwright

Management Magazine says in any church or organization:

10% are innovators

80% are conservative, but will change when the facts are shown and proven

10% are inhibitors and refuse to change.

Spiritual Circumcision: "Cutting away everything from life, but the will of God." John MacArthur

"No pressure is greater than God's power." Charles Swindoll

"God never said doing His will would be easy; He only said it would be worth it." Joanne Shetler, Missionary

"Where ever you are, be all there." Jim Elliott

John 3:16 reveals the breath, length, depth, and height of God's love. (Repeat the verse slowly in meditation).

"There is nothing worth living for, unless it is worth dying for." Elizabeth Elliott

"The sum of all wisdom is the knowledge of God and of ourselves." John Calvin

"The temptations of Satan always have another side; it is the testings of God." Ruth Paxson

The first reformation restored the Bible to the people. We are in the second reformation -- restoring the ministry to the people.

"God works through men. I see no where in the Word where God picks an organization." Dawson Trotman

"The believer does not use God's power; God's power uses him." Kenneth Wuest

"HUMILITY is to expect nothing, to wonder at nothing done to us; to feel nothing against us. It is to be at rest when nobody praises us and when we are blamed and despised. It is to have a blessed home in the Lord where we can go in and shut the door and kneel to our Father in secret, and be at peace when all around is trouble." Andrew Murray

"Follow-up is personal. It must be done by some ONE; not by some THING. For it to be effective we must set the pace. We can't permanently sell something we don't make time to get into our lives." Dawson Trotman

# THE NEEDS OF A BABY

Eph. 4:11-16

## I. A Baby Must Learn How To Eat. I Pet. 2:2,3; Job 23:12

- A. Three phases in eating.
  1. Someone feeds you.
  2. You learn to feed yourself.
  3. You learn to feed others.

## II. A Baby Must Learn How To Talk.

You don't learn to pray by listening to lectures, in a classroom setting. Prayer "is caught more than taught". Being exposed to someone who knows how to pray in faith is essential to growth in prayer.

## III. A Baby Must Learn How To Walk.

To walk is to obey! John 14:21; 15:10,14; Gen. 22:18; Amos 3:3; Eph. 5:2,15; II Cor. 5:7; I John 2:6; Col. 2:6.

## IV. A Baby Must Learn How To Share!

- A. To share is to witness. I John 1:3
  1. Ourselves
  2. Time
  3. What we have - money, home, etc.

Must teach how to share testimony. Write it out - keep it down to 3 minutes.

# THE DYNAMICS OF PERSONAL FOLLOW-UP

## I. Develop A Relationship.

- A. Through an atmosphere of loving concern - Prov. 17:17.
- B. Through patience.
- C. Through spending time together - Prov. 18:24.
- D. Be interested in more than just his spiritual life.
- E. All relationships should be built around knowing Christ - I John 1:3

## II. Minister To The Total Man - II Tim. 3:16,17.

Apply the Word to emotional, physical, social and spiritual needs and problems.

Examples: The person may be blunt, loud or a show off. Maybe he has developed a manner of social behavior which is unacceptable to others but he does not realize it. The best thing to do is sit down with him and in love and concern with gentleness explain how he appears to others.

There may be marital problems or need for counsel on courtship, financial difficulty, hygiene problems, etc.

## III. Balance Is Necessary In Follow-Up.

- A. We must meet their needs in three different forms.
  - 1. Real needs.
  - 2. Felt needs.
  - 3. Unconscious needs.
- B. It is necessary to impart not only teaching but counseling and encouragement.

## IV. Follow-Up Must Include Goals.

Abraham Lincoln said in 1885, "If we could first know where we are, and whither we are tending, we could better judge what to do and how to do it." Someone else said, "People don't plan to fail, they fail to plan.

- A. Some possible goals in their probable order of achievement.
  - 1. Assurance of salvation and standing in Christ.
  - 2. Consistency in the fundamentals.
    - a. Devotional life.
    - b. How to pray.
    - c. How to study the Bible alone.
    - d. How to practice confession.
    - e. How to have victory
    - f. How to share faith.
    - g. Importance of church.
    - h. Importance of cultivating Christian fellowship.

3. Stability in basic doctrine - Eph. 4:14.
4. Developing Christlikeness - Gal. 4:19. This will be the product of both counseling and teaching on the basic ingredients of the Spirit-filled life.
5. Independently applying and benefiting from the Word of God.

**V. Achieving Goals In Follow-Up ministry.**

- A. Define in more detail the content of the goals.
  1. Devotional area - this is the topic area of personal follow-up training related to the growth and development of Christlikeness in a new believer's life.
  2. Doctrinal area - This is the topic area of personal follow-up training related to the impartation of biblical, doctrinal, and related knowledge in the new believer's life.
  3. Discipleship area - this is the topic area of personal follow-up training related to developing expertise in Christian services in the areas of witnessing, teaching and follow-up in a new believer's life.
- B. Develop Curriculum.
  1. Devotional area - following is a list of topics that must be covered in a total program of follow-up.
    - a. Salvation
    - b. Assurance
    - c. Devotions
    - d. Prayer
    - e. Memory
    - f. Bible study
    - g. Confession
    - h. Temptations
    - i. Holy Spirit
    - j. Obedience
    - k. Discipline
    - l. Habits
    - m. Guidance
    - n. Stewardship
    - o. Church
  2. Doctrinal area.
    - a. Doctrine: Refers to the need of a basic level of systematized doctrinal knowledge in a new believer's life.
    - b. Systematized Biblical Knowledge: Refers to the need of a systematic knowledge of the content of the Word of God.
    - c. Apologetics: Refers to the knowledge needed in the area of making a defense of the Christian faith.
    - d. Counseling: Refers to the knowledge needed in knowing how to use the Word of God to solve problems.
  3. Discipleship area.
    - a. Knowledge of how to share the faith. Must be more than merely challenging a person to share their faith, must also train them to do it.

- b. Developing an evangelistic testimony. A personal testimony relating the change Christ made in a life is a powerful force in lending credibility to the Gospel.
  - c. Follow-up training. Helping him now to understand the importance of the very things that have been taught him so that he might in turn pass them on to the fruit God has given him.
  - d. Biblical counseling. When a person begins to follow-up others, he should also begin to learn how to deal Biblically with problems in the life of a new believer.
  - e. Working knowledge of Apologetics. Theory of defense is not enough, now there must be practicality - I Pet. 3:15.
  - f. Time management. Teaching on priorities and training in scheduling time are needed.
- C. Schedule instruction - Prov. 16:3.
- 1. One on one.
    - a. All topics in devotional area
    - b. Evangelism
    - c. Testimony
    - d. Outreach training.
  - 2. Personal study.
    - a. Apologetics
    - b. Bible study
    - c. Understanding cults
    - d. Scripture memorization
  - 3. Group teaching.
    - a. Doctrine
    - b. Bible teaching
    - c. Counseling
    - d. Missions

# THINGS TO REMEMBER IN PERSONAL DISCIPLING

NOTES BY ROY ROBERTSON

1. Be loving, but don't "baby" your Timothy; some may tend to want to smother your time.
2. In building a group of Timothys, don't play favorites. Be harder on those you have a natural affinity for.
3. Correct immediately. ECC. 8:11
4. Get ALL the facts before judging or accepting an accusation about one of your Timothys. Make no accusations before a close check up. Prov. 18:13
5. Keep regular appointments with your Timothy. If they cannot come insist they call you; always check up to see if they have completed assignment. Sometimes a cancelled meeting really means unfaithfulness in getting the job done. Luke 16:10
6. CHECK-UP. Use it. Give them a goal. Insist they make it. I need and WANT leverage. And I put myself UNDER a person to keep the pressure on.
7. Give assignments that will stretch you Timothy, however, "the desire accomplished is sweet to the soul". You want them to succeed. A small assignment sometimes allows greater discussion time. NEVER break their confidence in not being hard on them if they fail to do any assignment. Start small; keep your training standards HIGH.
8. Share your heart and vision; they want to know.
9. Remember your responsibility and vision to set the pace. There must be the "sharp edge" of conviction and application of the Word to the daily life in you.
10. NEVER FORGET: USE THEM OR LOOSE THEM.
11. Ask the Lord to make you aware of special needs in their lives for lengthy prayer together. Prayer transmits love and burden rapidly.
12. In team relationships, don't allow different Timothys to get away with criticism. And in dealing with cultural differences remember, you can't change the Bible to fit a "custom" of the country. The Word is for all. Continue to show them God's standards from the Bible.
13. Never use a double standard; color makes no difference in standards of leadership.
14. Always have your Timothy give BACK to you what you have shared. Teach them to "commit to memory for RECALL". So many learn things for the NOW. Attitude is vital here. Stress the assignments are not just for their growth, but for the Timothys they will be discipling too.
15. Let the Timothy feel he is a vital part of your work and ministry. NO ONE CAN KEEP YOU FROM GOD'S BEST BUT YOU. Ps. 75:6,7

# BUILDING DISCIPLES

## I. Building Toward Godly Character - I Tim. 4:12-16.

- A. Character is not a matter of age - Job 32:8,9; Ps 119:98.
- B. How one talks reveals inner character - I Tim. 4:12.  
Timothy was warned to be an example in word. This includes teaching and verbal communication of every kind. One's words reveals one's heart. Learn to read a person's heart in their words.
- C. Character expresses itself in conduct - I Thess. 4:7; I Peter 1:15,16. "Conversation" here means "conduct".
- D. A godly character has Godly attributes. These attributes are love, faith and purity - I Tim. 4:12
- E. Godly character needs to be fed. This is done by reading (v. 13) and by meditation (v. 15) and also through the other methods of taking in the Word.
- F. One's ministry is developed along the lines of one's spiritual gifts - I Tim. 4:14.
  - 1. Everyone has at least one spiritual gift - Heb. 2:4; I Cor. 12:7.
  - 2. No one has all the gifts - I Cor. 12:28-30.
  - 3. Gifts are given for the good and for the helping of the local body of Christ.
  - 4. Gifts are not a mark of spirituality - I Cor. 1:7. The church in Corinth had every spiritual gift operating, but were scathingly condemned the most by Paul for their immaturity and carnality - I Cor. 3:1-3.
  - 5. How to help a person discover gifts.
    - a. What does the person like to do?
    - b. What does God bless that they do?
    - c. How do others see them?
- G. Wholeheartedness is a mark of Godly character - I Tim. 4:15.
- H. Godly character must be protected - I Tim. 4:16; Matt. 26:41; I Cor. 16:13.
- I. Godly character is recognized by others - I Tim. 4:15b; Matt. 5:16.
- J. The root from which Godly character springs is the thought life - I Tim. 4:16. The mind is the real battleground - Prov. 4:23; Eph. 4:23,24; Rom. 12:2.
- K. Godly character makes daily choices - I Tim. 4:16; Luke 9:23.
- L. God blesses Godly character - I Tim. 4:16.
- M. God uses those with Godly character to help others - I Tim. 4:16
- N. God's standard operating procedure is to change lives and build character - Titus 1:1,2; Col. 1:6.

## II. Building Begins With Clearing Away The Obstacles To Progress - Jerm. 1:10.

- A. Root out bitterness, hostility and fear - Heb. 12:15.
- B. Pull down idols - Hosea 10:2; Col. 3:5.
- C. Destroy bad responses - Phil 4:11; Luke 1:38.
- D. Throw down ungodly imaginations - II Cor. 10:3-5; Prov. 23:7.

## III. Clearing Away The Obstacles Involves Correction.



*Correction is only respected and appreciated when the relationship with the other person is solid and established. The person must know that you love them and that you are pointing out problems not to be critical, but to be helpful - Ez. 3:20.*

A. What II Tim. 4:2 says about correction.

1. **Reprove.** This means to expose something in a person's life, developing the conviction that it is a sin. This is the work of God by the Holy Spirit.
2. **Rebuke.** This means to literally "bawl one out" for letting the matter reach such a state of deterioration.
3. **Exhort.** This is always connected with the future, not the past, and it is designed to help correct the problem. Exhortation aims at producing the right effect in changing a life.
4. The scripture is adequate and sufficient within itself in doing all the above things - II Tim. 3:16.

B. Five principles of rebuke. There must always be a proper balance between rebuking a person and loving them.

1. If you do love a person, you will rebuke them. But it is two way. The person must be committed to you and you must be committed to them. If you rebuke, you must be willing to receive rebuke.
2. Find out why the person is walking in error. Generally, you will find one of three reasons.
  - a. The person does not see the thing.
  - b. The person is in rebellion.
  - c. The person is trying to obey but cannot.
3. Rebuke on the basis of impression, not accusation. Give the person the opportunity to explain the situation without being accused. Do not self-appoint yourself to God's Gestapo. Your self-righteous condemnation of others will bring an equal judgment against yourself.
4. Always rebuke using the Word of God as the standard for correct behavior. It is the basis of our authority.
5. Be sure you have the disciple's best interest at heart. Be sure you don't have any anger, animosity or bitterness in you heart - Prov. 28:23.

#### **IV. Planting a New Structure Is Also Part Of The Building.**

A. Three helpful questions to ask yourself in this regard are:

1. What does the disciple need?
2. How am I going to help the person to learn it?
3. How will I know when it has been learned?

B. If it is concept you are trying to teach, the question would be:

1. What do I want the disciple to know?
2. How am I going to help the person to learn it?
3. How will I know when it has been learned?

C. If it is a training situation, the questions would be:

1. What skill do I want the disciple to develop?
2. How will I train the person in that skill?
3. How will I know when the skill has been acquired?

D. If it is in the area of character building, the questions would be:

1. What trait of character do I want the learner to develop.

2. How can I help build this trait into the disciple's life?
3. How will I know when this trait of character has become a part of that person's life?

**V. Everyone Is Different - I Thess. 5:11-14.**

*This passage speaks of spiritual leaders.*

- A. Who are spiritual leaders? V. 12,13.
  1. Those who labor among you.
  2. Those who are over you in the Lord.
  3. Those who admonish you. The Greek word for admonish is "noutheto" which means to comfort.
- B. How are we to respond to spiritual teachers? V. 13.
  1. Respect and esteem them highly.
  2. Respect them because of their work.
- C. How to treat different people? V. 14.
  1. The idle? Admonish them. Idle means those who are lazy and unruly. The Greek word for this indicates a military formation where one is out of step with the rest of the soldiers. It is rebellion - I Sam. 15:23.
  2. The faint hearted? Encourage them. These are the individuals who run out of steam. They are timid. They know how to do it and they would like to be able to do it, but they just don't have the courage and motivation.
  3. The weak? Help them. Apparently this speaks of the untrained. These are simply the people who don't know how to do it.
  4. Be patient with all people. Our difficulty in understanding those who are weak when we are strong is simply human nature. It seems so very obvious to us. Be patient.
  5. A strong warning here. The verse says to admonish the idle and lazy. Don't encourage them or they will remain lazy. Don't help them or they will sit down and let you do it all. Don't admonish the timid, those who know how to do it but just don't have the courage, because if you do, you will crush them. Don't help the timid because they already know how to do it. This will frustrate them and give them a greater guilt complex. Don't admonish the untrained person. Such a person can't help it. Such people don't know how to do it. What they need is training. In working with people remember that you may encounter these various types. This is why it is important to carefully determine where these disciples are.

**VI. Building Must be Specific And Of Primary Importance In The Area Of Decision-Making.**

- A. Making decisions. I Kings 18:21. God does not vacillate and He does not want His people to vacillate. In Revelation where God is speaking to the churches, five of them were reprimanded because of their indecision - II Cor. 1:17,18.
  1. Life is made up of choices and decisions; salvation, personal devotions, personal study, honesty, moral purity, honoring parents, honoring mate, etc.
  2. Indecisiveness may reveal five things about a person.

- a. It may reveal immaturity - Prov. 17:24.
  - b. It may reveal a lack of facts - Prov. 23:23.
  - c. It may reveal a fear of consequences or people - II Tim. 1:7; John 12:43; Matt. 25:25.
  - d. It may reveal lack of convictions - Col. 2:8. One who doesn't stand for something will fall for anything. Eph. 4:14.
  - e. It may reveal a lack of faith - Rom. 14:23.
3. Here are four helpful thoughts when indecisive:
- a. God wants me to know His will.
  - b. Do I know it? If so, I should trust Him and act on it.
  - c. Am I trying to find out? If not, I am kidding myself.
  - d. Have I found it out? If so, I must get busy and trust Him.
4. Here are six insights toward decisiveness.
- a. Get the facts - Prov. 23:23.
  - b. Face the facts - II Kings 5:11. Naaman "thought". One characteristic of straight thinking is facing the facts once you get the facts - Prov. 14:8. Doing nothing has consequences just as surely as doing something bad.
  - c. Plan ahead - Prov. 16:9; 11:14.
  - d. Think through - Prov. 22:3, 14:15. People who seem most balanced and most efficient when times get tough are the people who have figured out the very worst thing that can happen, have faced it and decided what to do if it does happen. Then anything else that happens will be an improvement.
  - e. Make a decision - I Cor. 14:8.
  - f. Do it now. This applies to all the above points. People who hesitate in making a decision are in a most unfortunate position. By remaining in the middle of the road, they face the danger of being run over by both lanes of traffic instead of just one.
- B. A positive outlook. - Phil. 4:8. Desiring something is more than just having a willingness to accept it if it comes your way. It is positive and purposeful and energetic and creative action.
- C. Perseverance. Most people differ less in capacity than in zeal and determination. They should utilize the powers they have. Great works are often performed not by strength but by perseverance.
- D. In your church and community. Building your own life is the greatest tool you can use with others - Phil. 4:9; II Tim. 3:10-14.

# BASICS FOR MOTIVATION

## I. Tell Them Why.

- A. Four things to do when you meet with one you are Discipling.
  - 1. Principles - Word of God must become the foundation standard. Share the Word.
  - 2. Progress - "Telling isn't teaching necessarily; nor is listening necessarily learning." After prayer together, check-up on previous assignment. "People do what we inspect not what we expect." Check-up teacher, faithfulness and diligence.
  - 3. Problems - The closer you get, the more the Spirit will make you aware of problems. Listen and take them to the Scriptures. Solutions must come from Scriptures. By confronting problems, you prevent future difficulties.
  - 4. Prayer - Pray for and with - Prayer list of specific prayer requests you make for that person.
  - 5. Projects - Practice together. Evangelism, visitation, etc.

## II. Show Them How.

- A. Parents and preachers tend to tell what to do rather than show "how". We learn to do by doing. A friend said - Ever try to tell how to tie a shoe-lace by writing instructions - works best to explain and show how!
  - 1. Teach them through responsibility. Personal involvement will result in heart commitment.
  - 2. Teach them through real exposure. The fastest way of involving a person in a learning experience is exposure to needs.

## III. Get Them Started.

- A. Be enthusiastic yourself. Your attitude is vital. Faith is infectious. Live discipling in the frame of Phil. 4:11-13,19.
- B. Intensify interpersonal friendships. The closer you are - the greater the potential.
- C. Accept them totally. What you are is more important to the person than what you say.

## IV. Keep Them Going.

- A. Teach and motivate by recognition and encouragement. Anyone can pick out the flaws in a person; it takes grace and insight to encourage. Ask God for His eyes.
- B. Balance with unconditional love. Love means meeting the deepest needs in the life of another; it is a commitment of the will to what is best for someone else as long as they live. Balance between graciousness of love and cutting edge of truth in the life of Christ. His love caused the disciples to follow Him.
- C. Check-up on assignments. We teach discipline by having goals and assignments ourselves, then going over theirs.

**V. Teach Them To Multiply.**

A. By your example and vision. I Thess. 1:5,6. It takes a disciple to build a disciple.

# HOW TO STUDY THE WORD OF GOD

II Tim. 2:15

Some important points that are beneficial to effective study of the Bible.

**I. Bible Study Must Be Consistent. Acts 17:11.**

**II. Bible Study Must Be Systematic.**

- A. Question and answer is usually best for a new Christian.
- B. Chapter analysis is recommended for a growing disciple.

**III. Bible Study Must Contain Original Investigation.**

- A. This means that we do not depend on the work of others, but commit ourselves to digging in the Word of God on our own.
- B. It is necessary to study the Bible - not about the Bible or simply to acquire Bible knowledge.
- C. There are some general questions that will help original investigation.
  - 1. What does the passage say? In your own words summarize or outline the passage under study.
  - 2. What does the passage say that I do not understand? In this step list the problems or difficulties of understanding or interpreting the passage verse by verse. This does not necessarily mean that you will find answers at the moment for every problem.
  - 3. What do other passages of Scripture say that help me understand this passage? This exercise is often called finding cross-references, other Scriptures that say the same thing, or in some way help explain the verse in the passage under study. This is usually done with the help of a concordance.

**IV. Bible Study Must Include Written Reproduction.**

- A. We reword what we have discovered in our searching.
- B. If a person does not record what he has studied, he has only read the Scriptures.

**V. Bible Study Must Have Application To Daily Living.**

- A. Bible study will have little value if we are not going to apply its teachings.
- B. The most important question in Bible study must be, Lord, what do you want me to apply to my life from this portion that I am studying?
- C. Personal application is one of the most neglected parts of Bible study.
  - 1. Many are satisfied with only an intellectual study of the Bible.
  - 2. We must quit deceiving ourselves and apply the Word of God. James 1:21-25.
- D. Personal applications in Bible study can be written using the following suggestions.
  - 1. State in your own words the truth of the verse or passage that clearly speaks to you.
  - 2. Tell clearly how you have missed the mark that the verse or passage teaches.
  - 3. Give a specific example of what you did wrong.

4. Write out how you will put into practice the teaching of the application verse or passage.
5. Set a date to check up on yourself to make sure you have carried out what you planned.

**IV. Bible Study Must Be “Pass-On-Able.”**

- A. It must result in insights or lessons that can be shared meaningfully with another person.
- B. The benefits of Bible Study are not something that we keep for ourselves, but we pass them on in helping, edifying and strengthening others.

# RUN THE RACE

Heb. 12:1-4

“At the Olympics, glory doesn’t only go to those who win. Dorando Pietri was in a state of collapse as he entered the stadium for the final yards of the 1908 marathon. The Italian fell five times before an official helped him cross the finish line. Pietri was disqualified, but his indomitable spirit made him an international celebrity. A similar display of courage enabled Derek Redmond of Great Britain to finish the 400 meters in ’92. Hobbled by a torn hamstring near the half-way point, Redmond hopped the rest of the way with the help of his father, Jim, who rushed from the stands to aid his son. And who could forget the sight of Tanzania’s John Stephen Akhwari, his right leg bloody and bandaged, staggering into the stadium more than an hour behind the winner of the ’68 marathon? ‘My country did not send me to Mexico City to start the race,’ he said. ‘They sent me to finish the race.’”

Bud Greenspan *100 Greatest Moments In Olympic History*

None of these men won the race, but they won the hearts of the people. Why? They demonstrated courage and perseverance in spite of adverse circumstances. Ordinary people can accomplish extraordinary things.

**An Example:** John Wesley.

Ordained at age 24, was active for 64 years, died at 88. Preached total of 42,400 sermons. Average of 15 per week for 54 years. Average pastor preaches 100 per year. At that rate, it would take the average pastor today 2,424 years to preach as many sermons as Wesley

Wesley traveled 290,000 miles in his lifetime. Equal to circling the globe over 10 times. It may not seem so many miles in our day of air travel, but remember Wesley either walked or rode horseback most of that distance.

His writings were prolific. The works of Wesley, including translations, amounted to over 200 volumes. In order to accomplish all this he daily died to himself, his own comfort, ease and will.

When he died at the age of 88 it is said that Wesley left a worn coat, a battered hat, a humble cottage, a tattered Bible and the Methodist Church.

Many people have what some call “destination disease”. They feel that if they could just meet the right person, gain the right position, get the right degree, earn the right income - everything would turn out the right way.

An event will not change a life (except for salvation).

A decision does not change a life; life change is a process. Change must become a discipline; change is a lifestyle.



# HOW TO RUN THE RACE

I Cor. 9:24-27

## I. Start Running. v.24

Not studying the race, not planning the race, not diagramming the race, not discussing the race - it is running the race.

Every Christian wants to hear "well done," but we have to "well do" first.

A person is never what he ought to be until he is doing what he ought to be doing.

Success comes to the person who does today what you were thinking about doing tomorrow.

Do not wait for feeling or motivation - just do it.

If you are waiting for everything to be just right, you will never get into the race.

Goal setting is important, goal doing is more important. The first two letters are **GO**.

Ninety-five percent of the people who have ever set goals have never reached them.

They were going to be all they wanted to be - tomorrow.

None would be kinder or braver than they - tomorrow.

A friend who is troubled and weary they knew, would be glad for a lift and they needed it, too.

And on him they would call and see what they could do - tomorrow.

Each morning they stacked up the letters to write - tomorrow.

And thought of the folks they would fill with delight - tomorrow.

The greatest of people they might have been ---

The world would have opened its heart to them, but in fact they passed on and faded from view.

And all they left when their life was left, was a mountain of things they intended to do - tomorrow

Selected

Procrastination is caused by our perception that doing a certain task will cause pain.

Why have we not followed through before on our resolutions?

Pain perception stems from four areas.

1. Fear of failure.

2. Fear of success.

When your dream exceeds your self-image, you will sabotage yourself.

3. Difficulty of the task.

The longer you hold back on a difficult task, the harder it will be to tackle.

4. Monotony or boredom.

We avoid events which are unpleasant, complex, or uninteresting - regardless of their priority.

Nine techniques to help overcome procrastination.

1. Break down tasks into smaller segments.
2. Set deadlines and stick to them.
3. Share your goal with a friend who will check on you.
4. Reward yourself for completing the task; punish yourself when you don't.
5. Use character scheduling to set specific times for unpleasant tasks.
6. Make a game of it.
7. Focus on benefits for completing it.
8. Pick a simple task or activity to begin the project.
9. Just do it.

Readers Digest, Dec. 1992

## II. "So Run, That Ye May Obtain." v. 24 Desire Excellence.

"Mediocrity isn't at root a national problem nor a corporate or institutional problem, nor a departmental problem, mediocrity is a personal problem. American education isn't a monolith; American education is made up of millions of students being taught by millions of teachers, assisted by millions of supporting staff, equipped by millions of manufacturers and editors and suppliers - all paid for by billions of dollars! Each of these facets of education isn't mediocre; but those of us who made decisions and appropriate funding for education may have been slipshod in our commitment to our work. Schools aren't mediocre; but some of us who are administrators or teachers, and our students, have been halfhearted about our management, our teaching, their learning. You see, mediocrity is first, a personal trait, a personal concession to less than our best, and individual lethargic resignation that says, 'I guess good enough is good enough.' Soon mediocrity metastasizes throughout the body politic, causing the nation to be at risk; but always remember, mediocrity begins with me!"

*D. Bruce Lodkelbie, Thomas F. Stoley Foundation*

We are mediocre, not because of talent.  
We are mediocre, not because of condition.  
We are mediocre, not because of bad luck.  
We are mediocre, not because of background.  
We are mediocre, not because of personality.  
We are mediocre, because of choice, OUR CHOICE!

"Quality is never an accident; it is always the result of high intention, sincere effort, intelligent direction and skillful execution; it represents the wise choice of many alternatives."

Willa A Foster

"Mr. William Johnson said, 'Quality is a race with no finish line.' He is correct. Competitive excellence requires 100 percent all of the time. If you doubt that, try maintaining excellence by setting your standards at 92 percent, or even 95 percent. People figure they're doing fine so long as they get somewhere near it. Excellence gets

reduced to acceptable, and before long, acceptable doesn't seem worth the sweat if you can get by with adequate. After that, mediocrity is only a breath away."

Chuck Swindoll

#### Four Attitudes of People That Focus on Excellence.

1. Attention to detail
2. Continual improvement.
3. Self discipline.
4. Personal high standards.

"Excellence is the gradual result of always striving to do better."

Pat Riley

### III. Get The Tools Necessary. V.25 Strict Training.

#### HOW TO TRAIN FOR THE RACE

- T - Trainer - This gives you enlightenment
- R - Resources - This gives you enablement.
- A - Application - This gives you experience.
- I - Inspiration - This gives you encouragement.
- N - Nourishment - This gives you energy.

Ninety-five percent of the people who hear a message do not follow through. Put resources in their hands while they are listening.

### IV. Maintain An Eternal Perspective. V.25 Incorruptible Crown.

To guard yourself from short-term failures, keep a long-term mindset.

Discipline In A Long - Distance Race.

Heb. 12:1-4

#### How To Maintain An Eternal Perspective.

1. Get serious about the race you are to run.
2. Get rid of excess baggage.
3. Let the Lord Jesus be your model.  
(The secret of His perspective and perseverance is that He never lost sight of where He was headed.)

A sociological study was once conducted asking people over the age of ninety-five one question, "If you could live your life over again, what would you do differently?" Three answers consistently re-emerged and dominated the results of the study.

These three answers were:

1. If I had it to do over again, I would reflect more.
2. If I had it to do over again, I would risk more.
3. If I had it to do over again, I would do more things that would live on after I am dead.

Haggai 1:5-7 is a picture of life for most people. You will note there is nothing eternal mentioned.

Do you know why you were born and what you were created to do? The answers to the following three questions will reveal the “real” you.

1. What do you cry about?
2. What do you sing about?
3. What do you dream about?

#### **V Plan Your Race By Setting Goals. v.26 No Goal = No Plan.**

The goal is not running to run - the goal is to run the race.

“Life without goals is like a race without a finish line.” Ed Trenner.

Set your goals on your potential, not your environment. (Do not let only what you have seen be the criteria for your goals).

Keep your goals out of reach, not out of sight (Publicly declare your goals).

Set personal growth goals. (Results and ministry outreach will then take place normally). (There is a difference between organizational goals and personal growth goals).

#### **GOAL REALITIES**

Other growth goals without personal growth goals = short term satisfaction.

Other growth goals with personal growth goals = long term satisfaction.

Goal Precept: What I received by reaching my goals was not nearly as important as what I became by reaching them.

Goal Balance: Should be 90% personal and 10% for your organization (church or ministry).

Get something on the inside before you try to give out!

Dig a well before drawing water! You cannot put out what you have not put in!

Put some money in the bank before you start writing checks.

God will not bless an empty head and an empty heart.

Make a commitment to personal growth - Make it priority - It will cost you.

#### **VI. Measure Your Effectiveness. V.26 Fruitless Activity.**

A person who beats the air cannot measure his effectiveness because he is engaged in a fruitless activity.

# Three Way Test For Success Goals

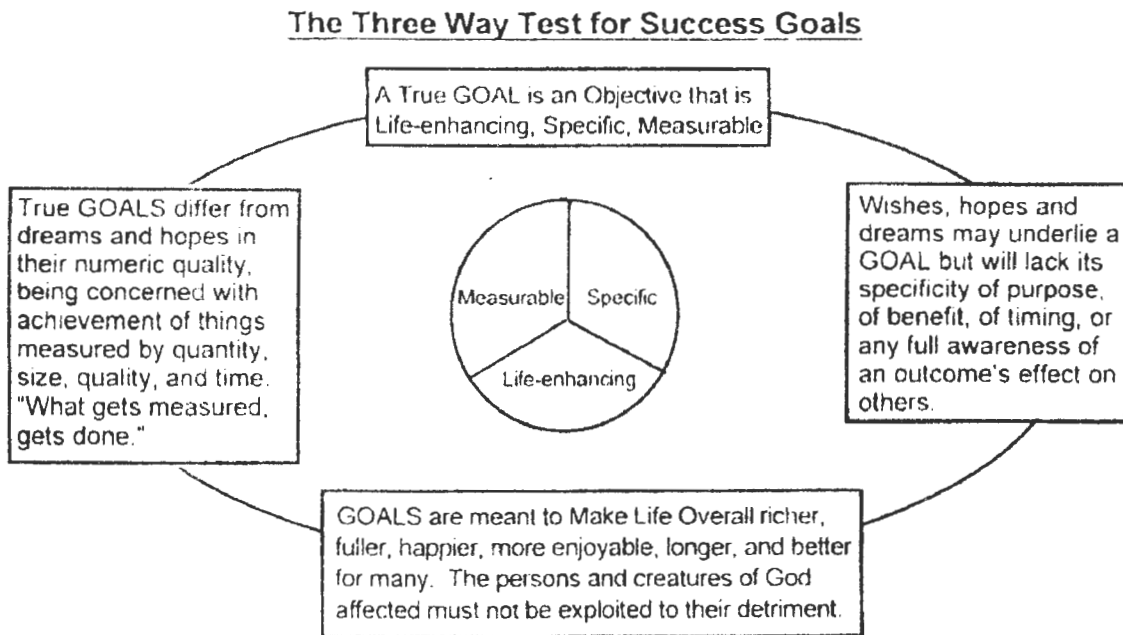

The way to tell if you have a correct goal is if it is specific, measurable and life-enhancing.

What you do with the first half of your life will determine the last half. The first half must be a positioning for the last lap - the finish line is at the end of the last half. Goals are important from the beginning.

A coach once said - "I want to have my team in a position to win with only 5 minutes left in the game."

## VII. **Preserver.** v, 27 "No One Is Safe Until They Are Home." H. A. Ironside.

*Perseverance is another name for success. An indispensable trait for one who wants to be used of the Lord is perseverance. Perseverance can be defined as: patiently enduring or overcoming difficulties.*

"Perseverance is characterized by three elements: Resilience, learned optimism, and opportunism.

Resilience is the ability to bounce back. Where does it come from? It comes from charged spiritual batteries, from a well-guarded emotional and physical reserve, and from the ability to laugh at oneself. Resilience also comes from a healthy dose of realism that is not surprised by obstacles.

Learned optimism can be defined as 'having an eye for what is going right.' Those who focus on failures and problems will not be able to hang in there for the long haul. If we

make the habit of thanking God for the things that are going well, we will approach each day with a renewed perspective.

Opportunism enables the pastor to see opportunities amid the problems. However pressing they are, take time to consider new ideas and new possibilities.”

Doug Murren, Pastor

**SECTION II**

**LESSONS FOR DISCIPLES**

)

)

)



# THE PLAN OF SALVATION

## **I. All Men Are Sinners.**

Rom. 3:10; 3:23; 5:12; I John 1:8.

## **II. Sin Has Its Wages.**

Rom. 6:23; 5:12,18; John 3:18,36.

## **III. Christ Came To Save Us.**

John 3:16; I Pet. 3:18; I Pet. 2:24.

## **IV. Christ Is The Only Answer.**

Acts 4:12; John 14:6.

## **V. Repentance Is Necessary For Salvation.**

Luke 13:3; Acts 17:30,31.

## **VI. Faith Is Necessary For Salvation.**

John 5:24; Eph.2:8,9; Rom. 4:5.

## **VII. It Is Necessary To Receive Christ. Now Is The Time.**

John 1:12; Rom. 10:9,10.

# AN EXAMINATION OF SALVATION

## **I. Have You Received Christ?**

John 1:12; Luke 18:13; Rom. 10:13; Gal. 3:26.

## **II. Have You Been Born Again?**

John 3:3; II Cor. 5:17; John 1:13; I Pet. 1:23.

## **III. Are You Obeying God?**

John 14:23,24; I John 1:6; 2:3,4.

## **IV. Do You Love The Brethren?**

I John 3:14.

## **VI. Do You Love The World?**

I John 2:15-17; James 4:4.

## YOU DECIDE

You are the one who has to decide,  
Whether you will do it or toss it aside.  
You are the one who makes up your mind,  
Whether you will lead or linger behind.  
Whether you will strive for the goal that's afar,  
Or be content to stay where you are.  
Take it or leave it, here's something to do!  
Just think it over, it's all up to you.

# ASSURANCE OF SALVATION

*When a person accepts Christ, the Bible teaches that they are saved. John 5:24. Salvation is a reflection of God. What God does is always perfect and complete. Salvation is perfect and complete and there is nothing that man can do or add to it. Salvation is not of works nor does it need good works to maintain it. It is necessary to accept the Word of God and not the teachings of men.*

## **I. Definition Of Eternal Life.**

Life without end or that never terminates - John 3:16; 3:36; 5:24.

## **II. The Believer Is Made A Son Of God.**

A son may bring disgrace to a family by his actions but he cannot cease being a son of that family - John 1:12; Gal. 3:26; 4:5; I John 3:1.

## **III. Some Say That The Doctrine Of Eternal Security Is A Dangerous Doctrine.**

Some say that if "once saved always saved" is true, then this gives license to sin because there is nothing to lose. The fact of regeneration is what changes this. A person who makes such statements as those above reveals his ignorance of the new birth. A saved person can do anything he wants to do and will not lose his salvation, but the fact is that his desires have been changed and the things that once were loved are now hated and the things that once were hated are now loved - II Cor. 5:17. If you do not have new desires, then you are not saved and need to accept Christ.

## **IV. A True Child Of God Is Always Punished When Sin Is Practiced Or Is Not Confessed And Abandoned - Heb. 12:6-8.**

If a person can sin and not experience the chastening, disciplining hand of God, this person is not saved. If a saved person sins and refuses to acknowledge his sin, it can cost his life - I Cor. 5:5; 11:30. "There is a sin unto death" - I John 5:16b.

Every believer dies for one of three reasons:

1. His work is finished.
2. For the Glory of the Lord.
3. Because of sin in his life.

May God help us to always walk with Him!

## **V. The Believer Is Safe In The Power Of God.**

He does not have to hold out or do anything to continue being saved or maintain his salvation - John 10:28,29; II Tim 1:12; Phil. 1:6; II Tim. 2:13.

**VI. When Christ Died On The Cross, He Pronounced The Words, "It Is Finished" Signifying That He Had Done All That Was Demanded By God The Father For The Eternal Salvation Of Mankind - John 6:28,29.**

**VII. If It Were Possible To Loose One's Salvation.**

It would be better to kill a person immediately after making a profession of faith before they have a chance to sin. The doctrine that one can be saved today and lost tomorrow is anti-Biblical - Eph. 2:8,9; 1 Cor. 1:30,31.

If you do not have the assurance of your salvation, surrender to Christ once and for all. Believe the verses presented in this study and do not believe your emotions or sentiment.

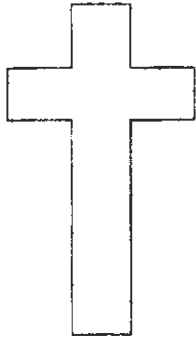

NOW THAT YOU HAVE BELIEVED IN CHRIST S  
WORK ON THE CROSS AND HAVE RECEIVED  
HIM AS YOUR SAVIOR...

**GOD HAS PROMISED TO YOU**

ETERNAL LIFE  
I JOHN 5:11-13  
JOHN 3:16

FORGIVENESS  
COL. 2:13  
I JOHN 1:9

SONSHIP  
GAL 3:26  
JOHN 1:12

**THINGS YOU SHOULD KNOW**

FACTS, NOT  
FEELINGS  
COL. 2:6

INNER WITNESS  
I JOHN 4:13  
ROMANS 8:16

NEW CREATION  
II COR. 5:17

**THINGS YOU WILL HAVE**

HUNGER FOR  
BIBLE STUDY  
I PETER 2:2

DESIRE FOR  
HOLY LIVING  
I JOHN 2:3

LOVE FOR  
OTHERS  
I JOHN 3:14

DESIRE TO  
TELL OTHERS  
ACTS 4:20

# **RESOURCES FOR VICTORY IN THE CHRISTIAN LIFE**

When a person is saved, Satan becomes very angry. He will attack the new believer. First of all, he will present doubts as to whether he was really saved or not. Suggestions will be made in thought "That was just too easy", "It is necessary to do more than just repent and trust Christ", "You can't really know whether you are saved until you get to heaven", "Only the Lord really knows whether you are saved or not", "Faith saves but, you have to hold out to keep saved".

Secondly, Satan will present opportunities to sin such as never before - I Cor. 10:13.

- I. The Word Of God - Ps. 119:11; John 17:17; I John 2:14; II Tim. 3:16,17.**
- II. Prayer - Heb. 2:17,18; 4:15,16; 10:19-22.**
- III. The Prayer Of Christ - Heb. 7:25-28; John 17:9-11; 15:20; Luke 22:32.**
- IV. The Holy Spirit - I Cor. 3:16; II Cor. 6:16; I Cor. 6:19,20; Zech. 4:6; John 14:26; 16:7; Rom. 8:26-27.**
- V. A Christian Assembly - The Church - Heb. 10:23-25.**

Church services are designed in the plan of God to strengthen one's faith and stimulate Christians to a daily walk with the Lord.

# **CHRISTIAN GROWTH**

## **PART I**

II Peter 3:18; Heb. 5:11-14; I Cor. 3:1-3; Eph. 4:11-16; Luke 7:31-35.

### **MANIFESTATION OF IMMATURITY**

- I. Place That Playing Occupies With A Child - I Cor. 13:11.**
- II. Immaturity Manifests Itself In Egotism - James 2:8,9; Matt. 20:20; II Cor. 5:15.**
- III. Immaturity Manifests Itself In Interest In The Flesh -Rom. 15:1,3; Phil. 2:21.**
- IV. Immaturity Manifests Itself In Its Inability To Handle Responsibility - Rom. 13:11,12; I Thess. 5:5-8.**
  - A. Failure to testify with life.
  - B. Failure to witness with mouth.
  - C. Failure to tithe and give offerings.
  - D. Failure to be obedient.
  - E. Lack of discernment.
- V. Immaturity Manifests Itself In A Lack Of Gratitude - II Tim. 3:2; I Thess. 5:18; Eph. 5:20; Col. 4:2.**
- VI. Children Are Easily Offended - I Cor. 13:11.**
- VII. Children Have A Short Span Of Concentration - I Cor. 13:11; I Tim. 4:12,13, 15,16.**

# CHRISTIAN GROWTH

## PART 2

II Peter 3:18

FOUR THINGS ARE NECESSARY FOR NORMAL GROWTH PHYSICALLY.

### I. **Food - I Peter 2:2,3; Jerm. 15:16; Ps. 119:97; Jos.1:8; Ps. 1:2,3.**

- A. We must have a balanced intake of the word.
- B. Hand illustration:
  - 1. Hearing - Rom. 10:17.
  - 2. Reading - Acts 17:11.
  - 3. Study - II Tim. 2:15
  - 4. Memorization - Prov. 3:1-4.
  - 5. Meditation - I Tim. 4:15; Ps. 119:97.
- C. Are you eating the Word for yourself or are you only taking in what someone else has chewed up for you and put into your mouth?
- D. The Word is:
  - 1. Light for our understanding - Ps. 119:105.
  - 2. Mirror for self-revelation - James 1:23.
  - 3. Sword for our conflict - Eph. 6:17.
  - 4. Honey for our special delight - Ps. 19:10.
  - 5. Seed for our sowing - Luke 8:11.
  - 6. Gold to enrich us - Ps. 119:72.
  - 7. Milk for our nutrition - I Peter 2:2.
  - 8. Meat to strengthen us - Heb. 5:14.
  - 9. Hammer to break our stubbornness - Jerm. 23:29.
  - 10. Fire to purify us - Jerm. 23:29.
- E. Do you have problems in understanding the Word? It could be that:
  - 1. You do not have the Holy Spirit - Eph. 1:13; 1 Cor. 2:14; John 14:17; 16:13.
  - 2. You have sin in your life - II Sam. 22:26; Matt. 5:8; John 7:17.
  - 3. God has led you to a place or a truth and you have failed to appropriate and apply it to your life - Deut. 29:29; Is. 66:2. God will lead you no more into the Word until you apply and are faithful to obey that which has been revealed to you.

### II. **Breathing - Lam. 3:56; I Thess. 5:17; I John 5:14,15.**

- A. How can we pray according to the will of God?
  - 1. To the Father - John 16:23.
  - 2. In the name of Christ - John 16:24.
  - 3. In the Spirit - Eph. 6:18.
  - 4. In faith - Heb. 11:6; James 1:5-7.
  - 5. With patience - Luke 18:1, 8; Matt. 7:7,8.
  - 6. Not to be seen or heard of men - Matt. 6:7.



- B. Illustration: The hand reveals the order of New Testament praying.
  1. Confession - Ps. 66:18; Prov. 28:13; Ps. 32:5; I John 1:9.
  2. Praise - Ps. 145-150.
  3. Thanksgiving - I Thess. 5:18.
  4. Intercession - Gen. 18:23-33; Eph. 6:18; Col. 4:12; James 5:16; I Sam. 12:23; Rom. 10:1.
  5. Petitions - Matt. 21:22; John 16:24.
- C. He that is not saved cannot pray - he can only pray the sinner's prayer - Luke 18:13; Rom. 10:13.

### III. Exercise.

- A. It is necessary for the proper development of the human body and for strength and the making of muscles. Appropriation and application of the Word is spiritual exercise for the believer - James 1:22-25; Prov. 23:7; Matt. 6:21; 12:34; 15:18,19; Luke 6:45; II Cor. 10:3-5; Prov. 3:1-4; 2:1-12; 4:21,22; Ps. 119:9,11; II Cor. 3:1-3,18.
- B. Examples of the use of the Word.
  1. In times of doubt - I John 5:11,12; Rom. 14:23.
  2. In temptation - I Cor. 10:13.
  3. Sin in the life - I John 1:9.
  4. Need to remember promises - II Cor. 1:21.
  5. Things the Lord has for His own - I Cor. 2:9.

### IV. Rest.

- A. The human body is seriously affected by a lack of rest - Heb. 3:7-4:11 (cross reference with Num. 13:28-33).  
*God had done many things for Israel. Example: His manifestation through preserving Israel, hearing their cry, preparing a leader, plagues, death of the first-born, liberation from Egypt, specific direction and guidance revealed by cloud by day and fire by night, crossing the Red Sea, going before them, fighting their battles for them, delivering their enemies into their hands, supplying water, manna, and quail, preserving their clothes, etc.*
- B. Promises:  
 Every promise in the book is mine. There is a promise for every need in the life. There are more than 30 thousand promises in the Bible for the believer now in time - I Cor. 2:9; II Cor. 1:21; Gen. 18:14; Job 42:2; Jerm. 32:17; Zech. 8:6; Matt. 19:26; Luke 1:37; Rom. 8:32; II Cor. 9:8;12:9; Eph. 3:20; Phil. 4:13,19.

# **JESUS CHRIST IS THE SUPREME WONDER OF THE BIBLE**

The Old Testament conceals Christ,  
The New Testament reveals Christ.  
The Old Testament enfolds Christ,  
The New Testament unfolds Christ.  
The Old Testament promises Christ,  
The New Testament presents Christ.  
The Old Testament pictures Christ,  
The New Testament produces Christ.  
The Old Testament symbolizes Christ,  
The New Testament sacrifices Christ.  
The Old Testament prophesies Christ,  
The New Testament proclaims Christ.  
The Old Testament is law, which Christ fulfilled,  
The New Testament is love, which Christ exhibits.

## **JESUS THE WONDER OF IT ALL!**

The secret of the unity of the Bible is Jesus.  
The secret of the strength of the Bible is Jesus.  
The secret of the beauty of the Bible is Jesus.  
He is the Alpha - and the Omega,  
He is the first and the last.  
Take away the Bible - and you take away Christ.  
Take away Christ and you take away the foundation of our lives.

**LEARNING TO  
PRAY  
PHIL. 4:6,7**

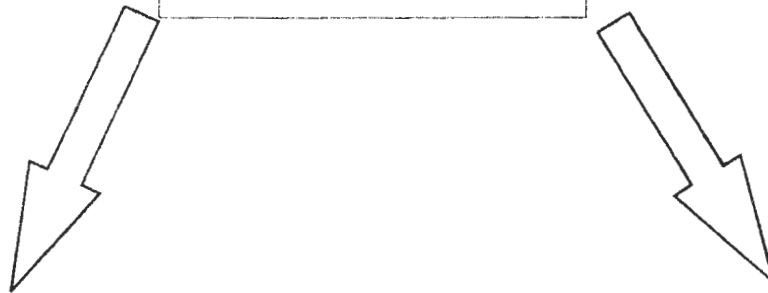

**PURPOSES FOR PRAYER**

1. Satisfies Inner Needs
2. Guidance
3. Deals with Worry
4. Converse with God
5. Defeat Sin

**INCREASE YOUR  
EFFECTIVENESS**

1. be Well Rounded
2. Be Systematic
3. Be Consistant
4. Be Specific
5. Be Persistant

GOD

HINDERANCES



MAN



1. NOT PRAYING IN FAITH  
JAMES 1:5-8
2. NOT ASKING  
MATT 21:22
3. ASKING FOR WRONG REASON!  
JAMES 4:3
4. UNCONFESSED SIN  
PS 66:18
5. REQUEST NOT IN GOD'S WILL  
I JOHN 5:14, 15

**HAVING DEVOTIONS**

**I PET 2:2  
PS 1:1-2  
II TIM 2:15  
II TIM 3:16-17  
MARK 1:35**

**PROCEDURE**

1. READ A CHAPTER OR PARAGRAPH.
2. BE SYSTEMATIC: GO THROUGH A WHOLE BOOK.

**PLAN FOR IT**

1. TIME
2. PLACE

**ASK QUESTIONS**

1. SINS TO FORSAKE?
2. PROMISES TO CLAIM?
3. EXAMPLES TO FOLLOW?
4. WARNINGS TO CONSIDER?
5. TEACHINGS ABOUT GOD?
6. OTHER IMPORTANT TRUTHS?
7. APPLICATIONS TO ME?

**PRAY**

1. DEVELOPE A LIST
2. EXAMPLE

DATE	REQUEST	ANSWER
	1.	
	2.	
	3.	
	4.	
	5.	

**KEEP  
A  
NOTEBOOK**

# PRA YER POSSIBILITIES

"ALL THINGS ARE POSSIBLE TO HIM THAT BELIEVETH"

Specific Request and Date	God's Answer & Date

"LEARN TO MOVE MEN, BY PRAYER ALONE TO GOD" - HUDSON TAYLOR

"GOD HAS NOT GIVEN US DISCERNMENT THAT WE SHOULD CRITICIZE, BUT THAT WE SHOULD INTERCEDE"

1971 W. B. MOORE

OSWALD CHAMBERS

# WORLD WIDE STRATEGIC INTERCESSION

NEED

REQUEST AS NEED RELATES TO ME.  
WHAT IS MY FIRST STEP?

# THE IMPORTANCE OF THE BIBLE

A disciple demonstrates faithfulness and a desire to learn and apply the Word of God through hearing it preached and taught, reading it frequently, Bible study, Scripture memory, and meditation on the Scriptures. II Tim. 3:16,17.

## I. Why God Gave Us The Bible.

The Bible is one of the means (the Bible, the Lord Jesus Christ and Creation) by which God has revealed Himself to mankind. In it are all the things we need to know for faith and practice. It is God's final and infallible Word about eternal life and about living in this world.

- A. The Bible reveals the God of Salvation to us. James 1:18; I Pet. 1:23; Rom. 15:4; Ps. 119:155; Acts. 20:32.
- B. the Bible guides and directs us through life. Ps. 37:4,5; Prov. 3:5,6; Ps. 119:105, 133
- C. The Bible empowers us in evangelism. II Cor. 5:19,20; Prov. 22:20,21; Ezek. 2:4; Ps. 126:6; Isaiah 55:10,11.
- D. The Bible helps us live the life of a disciple. II Tim. 3:16,17.
  - 1. A disciple needs teaching. Acts 18:11.
  - 2. A disciple needs rebuking. II Tim. 4:2.
  - 3. A disciple needs correcting.
  - 4. A disciple needs training in righteousness.

## II. How We Get To Know The Bible.

Note the hand illustration for the five means of intake of the Word of God.

- A. Hearing the Word of God. Rom. 10:17.
- B. Reading the Word of God. I Tim. 4:13.
- C. Studying the Word of God. II Tim. 2:15; Acts 17:11; Prov. 2:4.
- D. Memorizing the Word of God. Deut. 6:6; Prov. 7:2,3; Col. 3:16; Ps. 119:11.
- E. Meditating on the Word of God. Josh. 1:8; Ps. 1:2,3.

# GETTING THE WORD INTO THE LIFE

---

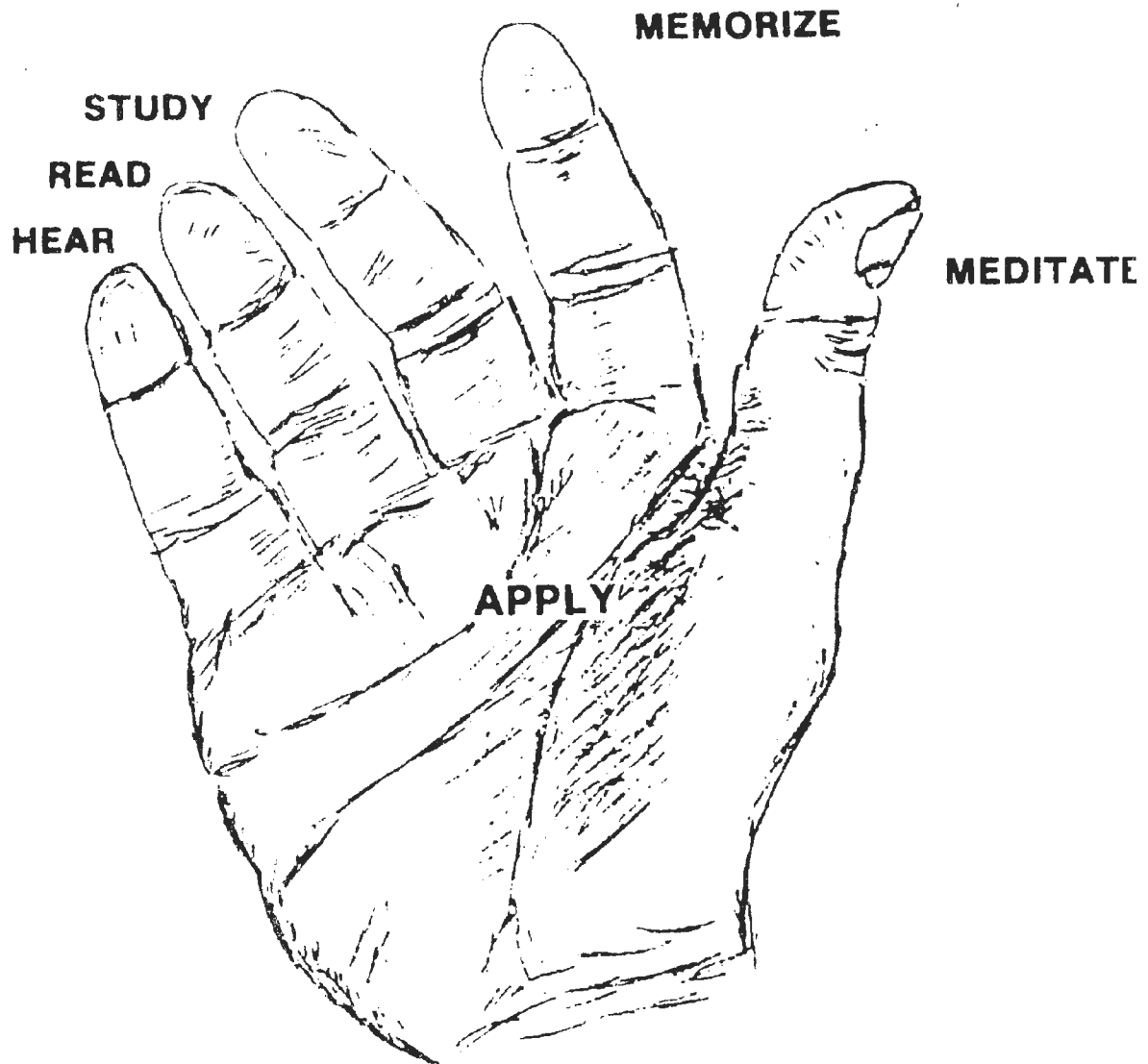

**HEAR** Rom. 10:17; Rev. 2:7,17

**READ** I Tim. 4:13; Rev. 1:3

**STUDY** Acts 17:11; II Tim. 2:15

**MEMORIZE** Ps. 119:11; Deut. 6:6; Prov. 7:1,3

**MEDITATE** I Tim. 4:15; Ps. 1:2; Josh. 1:8



# HOW TO HEAR GOD'S WORD AND REMEMBER

MARK 3:31-4:25

Jesus stated that those who do God's will are in a special relationship to Himself. Those who were listening to His preaching were singled out for encouragement; they were doing the will of God! (Mark. 3:31-35) Then, Jesus expounds the essentialness of hearing the Word in Mark 4. We forget about 90% of what we hear within 72 hours. It is not that we do not want to listen to God's Word; it is that we cannot retain it successfully. Taking message notes will dramatically increase both your ability to remember Scripture, and provide a daily method for its application to your life.

The word "sermon" is derived from a Latin word which means to "stick, stab, or thrust". Preaching is a channel by which God, through his chosen messenger, reaches into our hearts and brings us face to face with Himself.

## PREPARATION FOR REMEMBERING GOD'S WORD.

**PRAY** - Pray for your pastor as he prepares to share God's Word. Pray as you enter the auditorium. Ask God for an open heart, a thinking mind. "Speak Lord, for thy servant heareth."

**BRING YOUR BIBLE** - Follow along as the Scripture is read and shared. You may desire to mark key words; pencil in cross references. The Bible is a work book, a resource bridging the sermon and you life.

**BE ALERT** - It isn't always easy to concentrate. Satan would steal God's Word from bringing forth fruit in you heart. Take deep breaths; pinch yourself if you become drowsy. Fight!

**LISTEN** - Listening is hard work. It is a habit that must be cultivated. Sit close to the speaker. There is less to disturb and side-track you when you are in front. Concentrate on the content of the message rather than the speaker.

**TAKE NOTES** - Have the goal of taking back home into your life at least one idea from God you can use this week. Follow the sermon note sheet in the notebook. Write down ideas, verse references and sentences that speak to your heart. Abbreviate words when possible. When you hear something that touches your heart, concentrate on writing it down, then pick up the flow of the message again. Better to have one sentence than leave hearing all, remembering nothing. "Enjoying the message" is unimportant. Remembering what God has said and applying it is life and death to your spiritual growth.

**PERSONALIZE** - Generality is the death of application. Ask questions to yourself such as, "What are you saying to me now, Lord?" "What is the main lesson God is teaching?" or, "What one thing is God asking me to do to get this truth in my life this week?" Discuss the sermon (not the preacher) with others when possible. For family devotions with school age children, teach them to take sermon notes. Share Sunday morning's message for Monday night's family devotions. Sunday evening's message can be discussed and application sought for Tuesday evening's family time. "But be ye doers of the Word, and not hearers only, deceiving your own selves." James 1:22.

## **THE BIBLE IS A BOOK OF PRINCIPLES AND PROMISES MASTER ITS PRINCIPLES: CLAIM ITS PROMISES**

“First thing I do, crack out of the box, after a guy is saved, is teach him how to study the Bible.” Howard Hendricks

“Want to know what Jesus said? Read Matthew.  
Want to know what Jesus did? Read Mark.  
Want to know what Jesus felt? Read Luke.  
Want to know what Jesus was? Read John.  
How to know Christ? We know Him photographically in the Gospels, interpretatively in the Epistles, and experientially as the Word is fulfilled in you.” J. Sidlow Baxter

# PURPOSEFUL BIBLE READING

Reading the Bible daily can explode your spiritual growth potential (I Tim. 4:13-16). There are two main ways to read the Bible. Let us compare them to water skiing and pearl diving.

Some read their Bibles like a person water skiing. Covering territory, there is the exuberance of the waves, the wind, and shore line zooming past as one skis over the water. The skier's overview is panoramic. This Bible reader sees the scope and story of Scripture. He enjoys reading the Word, remembers the general points. Exploring is good.

The pearl diver, in contrast, plunges under the water to find oysters. He concentrates on the goal; pearls. Bringing the shells to the surface there is always the possibility of a pearl. The purposeful Bible reader like the pearl diver is looking specifically for things in the text of the Scripture. He will always find something of value, and occasionally discover a pearl from God's hidden treasures in the Word. There are many things in each verse to be revealed. In reading a chapter a number of times, coming up with fresh truth and insight with each reading. One way to master a book, read it at least 30 times, covering an average of four chapters a day. For example, Philippians is four chapters long. You will become immersed in it and begin to master its content and in turn be mastered by Christ in just 30 days. Each reading will be fresh as you use different topics. Record your pearls in the Daily Bible Reading pages of the Quiet Time Section of your notebook.

## **In reading look prayerfully for:**

1. The best verse in each chapter
2. What it says about the Lord
3. The main lesson
4. Promises from God to believe and claim
5. Commands to obey, now
6. Some new truth to praise God for in prayer
7. Some sin you can search your heart for
8. One thing from each day's reading you can carry through the day, applying to your life.

## **Or ask the following questions about the passage:**

1. What question must have been asked for the writer to say these things (especially good for letters of Paul, Peter and John)?
2. What is God saying to me today?
3. What decision will I make because God is speaking?
4. Summarize each chapter or passage under these headings: God, Jesus Christ, Holy Spirit, the church, church experience, the future, needs in my life.

Begin with five minutes of reading, five minutes of prayer. Let your time expand as capacity increases to grow. The Holy Spirit is the great teacher. He wants to reveal Christ, leading you into identification with His life and priorities. Begin each time of reading with a prayer for wisdom to see in the "mirror of the Word" the living Christ, forgiving, resurrected, reigning, returning.

Note: Let's break through the "mental block" some have on reading the Bible through in a year. If you read it by pages rather than chapters, here is what you will accomplish.

Number of pages daily	Number of days to read Bible through
220 pgs. Approx.	only 7 days
110 pgs.	Only 14 days
55 pgs.	Only 28 1/2 days
27 1/2 pgs.	Only 57 days
14 pgs.	Only 114 days

## “HOW READEST THOU?”

It is one thing to read the Bible through,  
Another thing to read to learn and do,  
Some read it as their duty once a week,  
But no instruction from the Bible seek;  
While others read it with but little care,  
With no regard to how thy read, nor where.  
Some read to bring themselves into repute,  
By showing others how they can dispute,  
While others read because their neighbors do,  
To see how long 'twill take to read it through,  
Some read it for the wonders that are there,  
How David killed a lion and a bear;  
While others read it with uncommon care,  
Hoping to find some contradictions there,  
Some read as if it did not speak to them,  
But to the people at Jerusalem.  
One reads with father's specs upon his head,  
And sees the thing just as his father said,  
Some read to prove a pre-adopted creed,  
Hence understand but little what they read;  
For every passage in the book they bend,  
To make it suit that all-important end.  
Some people read, as I have often thought,  
To teach the book instead of being taught;  
And some there are who read it out of spite.  
I fear there are but few who read it right.  
But read it prayerfully, and you will see,  
Although men contradict, God's Words agree,  
For what the early Bible Prophets wrote,  
We find that Christ and His apostles quote.  
So trust no creed that trembles to recall,  
What has been penned by one and verified by all.

# MORNING NEW TESTAMENT

## January

Date	Reading
1	Mat. 1
2	Mat. 2
3	Mat. 3
4	Mat. 4
5	Mat. 5:1-30
6	Mat. 5:31-48
7	Mat. 6
8	Mat. 7
9	Mat. 8
10	Mat. 9:1-17
11	Mat. 9:18-38
12	Mat. 10:1-23
13	Mat. 10:24-42
14	Mat. 11
15	Mat. 12:1-21
16	Mat. 12:22-50
17	Mat. 13:1-23
18	Mat. 13:24-43
19	Mat. 13:44-48
20	Mat. 14:1-21
21	Mat. 14:22-36
22	Mat. 15:1-28
23	Mat. 15:29-39
24	Mat. 16
25	Mat. 17
26	Mat. 18
27	Mat. 19
28	Mat. 20
29	Mat. 21:1-27
30	Mat. 21:28-46
31	Mat. 22:1-22

## February

Date	Reading
1	Mat. 22:23-46
2	Mat. 23:1-22
3	Mat. 23:23-39
4	Mat. 24:1-14
5	Mat. 24:15-31
6	Mat. 24:32-51
7	Mat. 25:1-30
8	Mat. 25:31-46
9	Mat. 26:1-25
10	Mat. 26:26-46
11	Mat. 26:47-75
12	Mat. 27:1-26
13	Mat. 27:27-45
14	Mat. 27:46-66
15	Mat. 28
16	Mark 1:1-20
17	Mark 1:21-45
18	Mark 2
19	Mark 3
20	Mark 4:1-20
21	Mark 4:21-41
22	Mark 5:1-20
23	Mark 5:21-43
24	Mark 6:1-13
25	Mark 6:14-41
26	Mark 6:32-56
27	Mark 7:1-23
28	Mark 7:24-37
29	Mark
30	Mark
31	Mark

## March

Date	Reading
1	Mark 8:1-21
2	Mark 8:22-38
3	Mark 9:1-29
4	Mark 9:30-50
5	Mark 10:1-22
6	Mark 10:23-52
7	Mark 11
8	Mark 12:1-17
9	Mark 12:18-44
10	Mark 13:1-13
11	Mark 13:13-37
12	Mark 14:1-25
13	Mark 14:26-52
14	Mark 14:53-72
15	Mark 15:1-23
16	Mark 15:24-47
17	Mark 16
18	Luke 1:1-25
19	Luke 1:26-56
20	Luke 1:57-80
21	Luke 2:1-35
22	Luke 2:36-52
23	Luke 3:1-20
24	Luke 3:21-38
25	Luke 4:1-30
26	Luke 4:31-44
27	Luke 5:1-16
28	Luke 5:17-39
29	Luke 6:1-19
30	Luke 6:20-49
31	Luke 7:1-18

## April

Date	Reading
1	Luke 7:19-35
2	Luke 7:36-50
3	Luke 8:1-15
4	Luke 8:16-39

## May

Date	Reading
1	Luke 22:1-27
2	Luke 22:28-53
3	Luke 22:54-71
4	Luke 23:1-26

## June

Date	Reading
1	John 10:1-21
2	John 10:22-42
3	John 11:1-26
4	John 11:27-44

5	Luke	8:40-56	5	Luke	23:27-45	5	John	11:45-57
6	Luke	9:1-21	6	Luke	23:46-56	6	John	12:1-22
7	Luke	9:22-43	7	Luke	24:1-12	7	John	12:23-50
8	Luke	9:44-62	8	Luke	24:13-35	8	John	13:1-20
9	Luke	10:1-24	9	Luke	24:36-53	9	John	13:21-38
10	Luke	10:25-42	10	John	1:1-14	10	John	14
11	Luke	11:1-23	11	John	1:15-34	11	John	15
12	Luke	11:24-38	12	John	1:35-51	12	John	16
13	Luke	11:39-54	13	John	2	13	John	17
14	Luke	12:1-15	14	John	3:1-21	14	John	18:1-18
15	Luke	12:16-41	15	John	3:22-36	15	John	18:19-40
16	Luke	12:44-59	16	John	4:1-13	16	John	19:1-30
17	Luke	13	17	John	4:14-39	17	John	19:31-42
18	Luke	14	18	John	4:40-54	18	John	20
19	Luke	15	19	John	5:1-27	19	John	21
20	Luke	16	20	John	5:28-47	20	Acts	1
21	Luke	17:1-19	21	John	6:1-21	21	Acts	2:1-24
22	Luke	17:20-37	22	John	6:22-59	22	Acts	2:25-47
23	Luke	18:1-17	23	John	6:60-71	23	Acts	3
24	Luke	18:18-43	24	John	7:1-13	24	Acts	4:1-22
25	Luke	19:1-27	25	John	7:14-36	25	Acts	4:23-37
26	Luke	19:28-48	26	John	7:37-53	26	Acts	5:1-16
27	Luke	20:1-26	27	John	8:1-11	27	Acts	5:17-42
28	Luke	20:27-47	28	John	8:12-35	28	Acts	6
29	Luke	21:1-19	29	John	8:36-59	29	Acts	7:1-19
30	Luke	21:20-38	30	John	9:1-20	30	Acts	7:20-40
			31	John	9:21-41			

## July

## August

## September

Date	Reading	Date	Reading	Date	Reading
1	Acts 7:41-60	1	Acts 27	1	I Cor. 11
2	Acts 8:1-25	2	Acts 28	2	I Cor. 12
3	Acts 8:26-40	3	Rom. 1	3	I Cor. 13
4	Acts 9:1-25	4	Rom. 2	4	I Cor. 14:1-22
5	Acts 9:26-43	5	Rom. 3	5	I Cor. 14:23-40
6	Acts 10:1-22	6	Rom. 4	6	I Cor. 15:1-19
7	Acts 10:23-48	7	Rom. 5	7	I Cor. 15:20-34
8	Acts 11	8	Rom. 6	8	I Cor. 15:35-58
9	Acts 12	9	Rom. 7	9	I Cor. 16
10	Acts 13:1-13	10	Rom. 8:1-17	10	II Cor. 1
11	Acts 13:14-39	11	Rom. 8:18-39	11	II Cor. 2
12	Acts 13:40-52	12	Rom. 9	12	II Cor. 3
13	Acts 14	13	Rom. 10	13	II Cor. 4
14	Acts 15:1-18	14	Rom. 11:1-12	14	II Cor. 5
15	Acts 15:19-41	15	Rom. 11:13-36	15	II Cor. 6
16	Acts 16:1-24	16	Rom. 12	16	II Cor. 7

17	Acts	16:25-40	17	Rom.	13	17	II Cor.	8
18	Acts	17	18	Rom.	14	18	II Cor.	9
19	Acts	18	19	Rom.	15	19	II Cor.	10
20	Acts	19:1-22	20	Rom.	16	20	II Cor.	11
21	Acts	19:23-41	21	I Cor.	1	21	II Cor.	12
22	Acts	20:1-16	22	I Cor.	2	22	II Cor.	13
23	Acts	10:17-38	23	I Cor.	3	23	Gal.	1
24	Acts	21:1-26	24	I Cor.	4	24	Gal.	2
25	Acts	21:27-40	25	I Cor.	5	25	Gal.	3
26	Acts	22	26	I Cor.	6	26	Gal.	4
27	Acts	23	27	I Cor.	7:1-24	27	Gal.	5
28	Acts	24	28	I Cor.	7:25-40	28	Gal.	6
29	Acts	25	29	I Cor.	8	29	Eph.	1
30	Acts	26	30	I Cor.	9	30	Eph.	2
			31	I Cor.	10			

### October

### November

### December

Date	Reading	Date	Reading	Date	Reading	
1	Eph.	3	1 Titus	2	1 II Peter	3
2	Eph.	4	2 Titus	3	2 I John	1
3	Eph.	5	3 Philemon	1	3 I John	2
4	Eph.	6	4 Heb.	1	4 I John	3
5	Phil.	1	5 Heb.	2	5 I John	4
6	Phil.	2	6 Heb.	3	6 I John	5
7	Phil.	3	7 Heb.	4	7 II John	1
8	Phil.	4	8 Heb.	5	8 III John	1
9	Col.	1	9 Heb.	6	9 Jude	1
10	Col.	2	10 Heb.	7	10 Rev.	1
11	Col.	3	11 Heb.	8	11 Rev.	2
12	Col.	4	12 Heb.	9	12 Rev.	3
13	I Thess.	1	13 Heb.	10:1-25	13 Rev.	4
14	I Thess.	2	14 Heb.	10:26-39	14 Rev.	5
15	I Thess.	3	15 Heb.	11:1-21	15 Rev.	6
16	I Thess.	4	16 Heb.	11:22-40	16 Rev.	7
17	I Thess.	5	17 Heb.	12	17 Rev.	8
18	II Thess.	1	18 Heb.	13	18 Rev.	9
19	II Thess.	2	19 James	1	19 Rev.	10
20	II Thess.	3	20 James	2	20 Rev.	11
21	I Tim.	1	21 James	3	21 Rev.	12
22	I Tim.	2	22 James	4	22 Rev.	13
23	I Tim.	3	23 James	5	23 Rev.	14
24	I Tim.	4	24 I Peter	1	24 Rev.	15
25	I Tim.	5	25 I Peter	2	25 Rev.	16
26	I Tim.	6	26 I Peter	3	26 Rev.	17
27	II Tim.	1	27 I Peter	4	27 Rev.	18
28	II Tim.	2	28 I Peter	5	28 Rev.	19



29	II Tim.	3	29	II Peter	1	29	Rev.	20
30	II Tim.	4	30	II Peter	2	30	Rev.	21
31	Titus	1				31	Rev.	22

## EVENING

### Old Testament

#### JANUARY

#### FEBRUARY

#### MARCH

Date	Reading	Date	Reading	Date	Reading
1	Gen. 1,2	1	Ex. 24,25,26	1	Num. 16,17
2	Gen. 3,4,5	2	Ex. 27,28	2	Num. 18,19
3	Gen. 6,7,8	3	Ex. 29,30	3	Num. 20,21
4	Gen. 9,10,11	4	Ex. 31,32	4	Num. 22,23
5	Gen. 12,13,14	5	Ex. 33,34	5	Num. 24,25
6	Gen. 15,16,17	6	Ex. 35,36	6	Num. 26,27
7	Gen. 18,19	7	Ex. 37,38	7	Num. 28,29
8	Gen. 20,21,22	8	Ex. 39,40	8	Num. 30,31
9	Gen. 23,24,	9	Lev. 1,2,3	9	Num. 32,33
10	Gen. 25,26	10	Lev. 4,5	10	Num. 34,35,36
11	Gen. 27,28	11	Lev. 6,7	11	Deut. 1,2
12	Gen. 29,30	12	Lev. 8,9	12	Deut. 3,4
13	Gen. 31,32	13	Lev. 10,11	13	Deut. 5,6
14	Gen. 33,34,35	14	Lev. 12,13	14	Deut. 7,8,9
15	Gen. 36,37	15	Lev. 14	15	Deut. 10,11
16	Gen. 38,39,40	16	Lev. 15,16	16	Deut. 12,13
17	Gen. 41,42	17	Lev. 17,18,19	17	Deut. 14,15,16
18	Gen. 43,44	18	Lev. 20,21	18	Deut. 17,18,19
19	Gen. 45,46	19	Lev. 22,23	19	Deut. 20,21
20	Gen. 47,48	20	Lev. 24,25	20	Deut. 22,23
21	Gen. 49,50	21	Lev. 26,27	21	Deut. 24,25,26
22	Ex. 1,2,3	22	Num. 1,2	22	Deut. 27,28
23	Ex. 4,5	23	Num. 3,4	23	Deut. 29,30
24	Ex. 6,7	24	Num. 5,6	24	Deut. 31,32
25	Ex. 8,9	25	Num. 7	25	Deut. 33,34
26	Ex. 10,11,12	26	Num. 8,9,10	26	Josh. 1,2
27	Ex. 13,14	27	Num. 11,12,13	27	Josh. 3,4,5
28	Ex. 15,16	28	Num. 14,15	28	Josh. 6,7
29	Ex. 17,18,19			29	Josh. 8,9
30	Ex. 20,21			30	Josh. 10,11
31	Ex. 22,23			31	Josh. 12,13

#### April

#### May

#### June

Date	Reading	Date	Reading	Date	Reading
1	Josh. 14,15	1	I Sam. 29,30,31	1	II Kings 13,14

2	Josh.	16,17,18	2	II Sam.	1,2	2	II Kings	15,16
3	Josh.	19,20	3	II Sam.	3,4	3	II Kings	17
4	Josh.	21,22	4	II Sam.	5,6	4	II Kings	18,19
5	Josh.	23,24	5	II Sam.	7,8	5	II Kings	20,21
6	Jud.	1,2	6	II Sam.	9,10,11	6	II Kings	22,23
7	Jud.	3,4	7	II Sam.	12,13	7	II Kings	24,25
8	Jud.	5,6	8	II Sam.	14,15	8	I Chr.	1,2
9	Jud.	7,8	9	II Sam.	16,17	9	I Chr.	3,4
10	Jud.	9	10	II Sam.	18,19	10	I Chr.	5,6
11	Jud.	10,11	11	II Sam.	20,21,22	11	I Chr.	7
12	Jud.	12,13,14	12	II Sam.	23,24	12	I Chr.	8,9
13	Jud.	15,16	13	I Kings	1	13	I Chr.	10,11
14	Jud.	17,18	14	I Kings	2	14	I Chr.	12,13
15	Jud.	19	15	I Kings	3,4	15	I Chr.	14,15
16	Jud.	20,21	16	I Kings	5,6	16	I Chr.	16,17
17	Ruth	1,2	17	I Kings	7	17	I Chr.	18,19,20
18	Ruth	3,4	18	I Kings	8,9	18	I Chr.	21,22
19	I Sam.	1,2	19	I Kings	10,11	19	I Chr.	23,24
20	I Sam.	3,4,5	20	I Kings	12,13	20	I Chr.	25,26
21	I Sam.	6,7,8	21	I Kings	14,15	21	I Chr.	27,28
22	I Sam.	9,10	22	I Kings	16,17	22	I Chr.	29
23	I Sam.	11,12,13	23	I Kings	18,19	23	II Chr.	1,2,3
24	I Sam.	14	24	I Kings	20,21	24	II Chr.	4,5
25	I Sam.	15,16	25	I Kings	22	25	II Chr.	6,7
26	I Sam.	17	26	II Kings	1,2	26	II Chr.	8,9,10
27	I Sam.	18,19	27	II Kings	3,4	27	II Chr.	11,12,13
28	I Sam.	20,21,22	28	II Kings	5,6	28	II Chr.	14,15,16
29	I Sam.	23,24,25	29	II Kings	7,8	29	II Chr.	17,18
30	I Sam.	26,27,28	30	II Kings	9:1-10;17	30	II Chr.	19,20
			31	II Kings	10:18,11,12			

## July

Date	Reading
1	II Chr. 21,22,23
2	II Chr. 24,25
3	II Chr. 26,27,28
4	II Chr. 29,30
5	II Chr. 31,32
6	II Chr. 33,34
7	II Chr. 35,36
8	Ezra 1,2
9	Ezra 3,4,5
10	Ezra 6,7
11	Ezra 8,9
12	Ezra 10
13	Neh. 1,2,3

## August

Date	Reading
1	Job 32,33,34
2	Job 35-38
3	Job 39-42
4	Ps. 1-7
5	Ps. 8-14
6	Ps. 15-18
7	Ps. 19-24
8	Ps. 25-30
9	Ps. 31-34
10	Ps. 35-37
11	Ps. 38-42
12	Ps. 43-48
13	Ps. 49-52

## September

Date	Reading
1	Ps. 139-144
2	Ps. 145-150
3	Prov. 1-4
4	Prov. 5-7
5	Prov. 8,9,10
6	Prov. 11,12,13
7	Prov. 14,15,16
8	Prov. 17,18,19
9	Prov. 20,21,22
10	Prov. 23,24,25
11	Prov. 26,27,28
12	Prov. 29,30,31
13	Eccl. 1,2,3

14	Neh.	4,5,6	14	Ps.	53-58	14	Eccl.	4,5,6
15	Neh.	7,8	15	Ps.	59-65	15	Eccl.	7,8,9
16	Neh.	9,10	16	Ps.	66-69	16	Eccl.	10,11,12
17	Neh.	11,12	17	Ps.	70-73	17	S. of S.	1-5
18	Neh.	13	18	Ps.	74-77	18	S. of S.	6,7,8
19	Esther	1,2	19	Ps.	78,79	19	Isa.	1,2
20	Esther	3,4,5	20	Ps.	80-85	20	Isa.	3,4,5
21	Esther	6,7,8	21	Ps.	86-89	21	Isa.	6,7,8
22	Esther	9,10	22	Ps.	90-94	22	Isa.	9,10
23	Job	1,2,3	23	Ps.	95-101	23	Isa.	11,12,13
24	Job	4,5,6	24	Ps.	102-104	24	Isa.	14,15,16
25	Job	7,8,9	25	Ps.	105,106	25	Isa.	17-20
26	Job	10-13	26	Ps.	107-110	26	Isa.	21,22,23
Ps.	Job	14,15,16	27	Ps.	111-117	27	Isa.	24,25,26
28	Job	17-20	28	Ps.	118:1- 119:72	28	Isa.	27,28,29
29	Job	21,22,23	29	Ps.	119:73-176	29	Isa.	30,31
30	Job	24-28	30	Ps.	120-131	30	Isa.	32,33,34
31	Job	29,30,31	31	Ps.	132-138			

## October

Date	Reading
1	Isa. 35,36,37
2	Isa. 38,39,40
3	Isa. 41,42,43
4	Isa. 44,45
5	Isa. 46,47,48
6	Isa. 49,50,51
7	Isa. 52,53,54
8	Isa. 55-58
9	Isa. 59,60,61
10	Isa. 62,63,64
11	Isa. 65,66
12	Jer. 1,2,3
13	Jer. 4,5
14	Jer. 6,7
15	Jer. 8,9,10
16	Jer. 11,12,13
17	Jer. 14,15,16
18	Jer. 17,18,19
19	Jer. 20,21,22
20	Jer. 23,24
21	Jer. 25,26
22	Jer. 27,28,29
23	Jer. 30,31
24	Jer. 32,33

## November

Date	Reading
1	Jer. 51,52
2	Lam. 1,2
3	Lam. 3,4,5
4	Ezek. 1,2
5	Ezek. 3,4
6	Ezek. 5,6,7
7	Ezek. 8,9,10
8	Ezek. 11,12
9	Ezek. 13
10	Ezek. 14,15
11	Ezek. 16
12	Ezek. 17,18
13	Ezek. 19,20
14	Ezek. 21,22
15	Ezek. 23,24
16	Ezek. 25,26
17	Ezek. 27,28
18	Ezek. 29,30
19	Ezek. 31,32
20	Ezek. 33,34
21	Ezek. 35,36
22	Ezek. 37,38
23	Ezek. 39
24	Ezek. 40,41

## December

Date	Reading
1	Dan 4
2	Dan 5
3	Dan 6
4	Dan 7,8
5	Dan 9,10
6	Dan 11
7	Dan 12
8	Hos. 1,2,3
9	Hos. 4,5,6
10	Hos. 7,8,9
11	Hos. 10,11
12	Hos. 12,13,14
13	Joel 1,2
14	Joel 3
15	Amos 1,2,3
16	Amos 4,5,6
17	Amos 7,8,9
18	Obad. 1
19	Jonah 1-4
20	Micah 1,2,3
21	Micah 4,5
22	Micah 6,7
23	Nahum 1,2,3
24	Hab. 1,2,3

25	Jer.	34,35	25	Ezek.	42,43	25	Zeph.	1,2,3
26	Jer.	36,37	26	Ezek.	44,45	26	Haggai	1,2
27	Jer.	38,39	27	Ezek.	46,47,48	27	Zech	1,2,3
28	Jer.	40,41,42	28	Dan	1	28	Zech	4-7
29	Jer.	43,44	29	Dan	2	29	Zech	8,9,10
30	Jer.	45-48	30	Dan	3	30	Zech	11-14
31	Jer.	49,50				31	Mal.	1-4

# BUILDING DISCIPLES BIBLE READING RECORD

MARK THROUGH THE SPACE OF EACH CHAPTER WHEN READ. USE DIFFERENT COLOR INK  
WHEN YOU FINISH THE CHAPTER AGAIN. PLACE THE DATE & YEAR YOU FINISH EACH BOOK  
BY ITS NAME.

## OLD TESTAMENT

GEN.	1	2	3	4	5	6	7	8	9	10	11	12	13	14	15	16	17	18	19	20
	21	22	23	24	25	26	27	28	29	30	31	32	33	34	35	36	37	38	39	40
EX.	1	2	3	4	5	6	7	8	9	10	11	12	13	14	15	16	17	18	19	20
	21	22	23	24	25	26	27	28	29	30	31	32	33	34	35	36	37	38	39	40
LEV.	1	2	3	4	5	6	7	8	9	10	11	12	13	14	15	16	17	18	19	20
	21	22	23	24	25	26	27													
NUM.	1	2	3	4	5	6	7	8	9	10	11	12	13	14	15	16	17	18	19	20
	21	22	23	24	25	26	27	28	29	30	31	32	33	34	35	36				
DEUT.	1	2	3	4	5	6	7	8	9	10	11	12	13	14	15	16	17	18	19	20
	21	22	23	24	25	26	27	28	29	30	31	32	33	34						
JOSH.	1	2	3	4	5	6	7	8	9	10	11	12	13	14	15	16	17	18	19	20
	21	22	23	24																
JUDG.	1	2	3	4	5	6	7	8	9	10	11	12	13	14	15	16	17	18	19	20
	21																			
RUTH	1	2	3	4																
I SAM.	1	2	3	4	5	6	7	8	9	10	11	12	13	14	15	16	17	18	19	20
	21	22	23	24	25	26	27	28	29	30	31									
II SAM.	1	2	3	4	5	6	7	8	9	10	11	12	13	14	15	16	17	18	19	20
	21	22	23	24																
I KING.	1	2	3	4	5	6	7	8	9	10	11	12	13	14	15	16	17	18	19	20
	21	22																		
II KING.	1	2	3	4	5	6	7	8	9	10	11	12	13	14	15	16	17	18	19	20
	21	22	23	24	25															
I CHR.	1	2	3	4	5	6	7	8	9	10	11	12	13	14	15	16	17	18	19	20
	21	22	23	24	25	26	27	28	29											
II CHR.	1	2	3	4	5	6	7	8	9	10	11	12	13	14	15	16	17	18	19	20
	21	22	23	24	25	26	27	28	29	30	31	32	33	34	35	36				
EZRA	1	2	3	4	5	6	7	8	9	10										
NEH	1	2	3	4	5	6	7	8	9	10	11	12	13							
ESTER	1	2	3	4	5	6	7	8	9	10										
JOB	1	2	3	4	5	6	7	8	9	10	11	12	13	14	15	16	17	18	19	20
	21	22	23	24	25	26	27	28	29	30	31	32	33	34	35	36	37	38	39	40
PSALM S	1	2	3	4	5	6	7	8	9	10	11	12	13	14	15	16	17	18	19	20
	21	22	23	24	25	26	27	28	29	30	31	32	33	34	35	36	37	38	39	40
	41	42	43	44	45	46	47	48	49	50	51	52	53	54	55	56	57	58	59	60
	61	62	63	64	65	66	67	68	69	70	71	72	73	74	75	76	77	78	79	80
	81	82	83	84	85	86	87	88	89	90	91	92	93	94	95	96	97	98	99	100
	101	102	103	104	105	106	107	108	109	110	111	112	113	114	115	116	117	118	119	120
	121	122	123	124	125	126	127	128	129	130	131	132	133	134	135	136	137	138	139	140
	141	142	143	144	145	146	147	148	149	150										
PROV.	1	2	3	4	5	6	7	8	9	10	11	12	13	14	15	16	17	18	19	20
	21	22	23	24	25	26	27	28	29	30	31									
ECCL.	1	2	3	4	5	6	7	8	9	10	11	12								
S. of S.	1	2	3	4	5	6	7	8												
ISAIAH.	1	2	3	4	5	6	7	8	9	10	11	12	13	14	15	16	17	18	19	20
	21	22	23	24	25	26	27	28	29	30	31	32	33	34	35	36	37	38	39	40
	41	42	43	44	45	46	47	48	49	50	51	52	53	54	55	56	57	58	59	60
	61	62	63	64	65	66														
JERM.	1	2	3	4	5	6	7	8	9	10	11	12	13	14	15	16	17	18	19	20
	21	22	23	24	25	26	27	28	29	30	31	32	33	34	35	36	37	38	39	40
	41	42	43	44	45	46	47	48	49	50	51	52								
LAM.	1	2	3	4	5															
EZ.	1	2	3	4	5	6	7	8	9	10	11	12	13	14	15	16	17	18	19	20
	21	22	23	24	25	26	27	28	29	30	31	32	33	34	35	36	37	38	39	40
	41	42	43	44	45	46	47	48												
DAN.	1	2	3	4	5	6	7	8	9	10	11	12								
HO.	1	2	3	4	5	6	7	8	9	10	11	12	13	14						
JOEL.	1	2	3																	
AMOS.	1	2	3	4	5	6	7	8	9											
OBD.	1																			
JONAH.	1	2	3	4																
MICAH.	1	2	3	4	5	6	7													
NAH.	1	2	3																	
HAB.	1	2	3																	
ZEPH.	1	2	3																	
HAG.	1	2	3																	
ZECH.	1	2	3	4	5	6	7	8	9	10	11	12	13	14						
MAL.	1	2	3	4																

If I read 7 pages daily I'll read the Bible through this year approx. 224 or 1 1/3 times a year.  
 If I read 14 pages daily I'll read the Bible through this year approx. 112 days or 3 times a year.  
 If I read 27 ½ pages daily I'll read the Bible through this year approx. 56 days or 6 times a year.  
 If I read 55 pages daily I'll read the Bible through this year approx. 28 days or 13 times a year.  
 If I read 110 pages daily I'll read the Bible through this year approx. 14 days or 26 times a year.  
 If I read 220 pages daily I'll read the Bible through this year approx. 7 days or 52 times a year.

### NEW TESTAMENT

MATT	1	2	3	4	5	6	7	8	9	10	11	12	13	14	15	16	17	18	19	20
	21	22	23	24	25	26	27	28												
MARK	1	2	3	4	5	6	7	8	9	10	11	12	13	14	15	16				
LUKE	1	2	3	4	5	6	7	8	9	10	11	12	13	14	15	16	17	18	19	20
	21	22	23	24																
JOHN	1	2	3	4	5	6	7	8	9	10	11	12	13	14	15	16	17	18	19	20
	21																			
ACTS	1	2	3	4	5	6	7	8	9	10	11	12	13	14	15	16	17	18	19	20
	21	22	23	24	25	26	27	28												
ROM	1	2	3	4	5	6	7	8	9	10	11	12	13	14	15	16				
I COR	1	2	3	4	5	6	7	8	9	10	11	12	13	14	15	16				
II COR	1	2	3	4	5	6	7	8	9	10	11	12	13							
GAL	1	2	3	4	5	6														
EPH	1	2	3	4	5	6														
PHIL	1	2	3	4																
COL	1	2	3	4																
I THES	1	2	3	4	5															
II THES	1	2	3																	
I TIM	1	2	3	4	5	6														
II TIM	1	2	3	4																
TITUS	1	2	3																	
PHIL	1																			
HEB	1	2	3	4	5	6	7	8	9	10	11	12	13							
JAMES	1	2	3	4	5															
I PET	1	2	3	4	5															
II PET	1	2	3																	
I JO	1	2	3	4	5															
II JO	1																			
III JO	1																			
JUDE	1																			
REV	1	2	3	4	5	6	7	8	9	10	11	12	13	14	15	16	17	18	19	20
	21	22																		

# DAILY BIBLE READING NOTES

Record: facts, ideas, devotional thoughts, application deeds. Use "Purposeful Bible Reading" suggestions.

"GIVE ATTENDANCE TO READING" I Tim. 4"13

DATE

# WHY MEMORIZE SCRIPTURE

1. We are commanded to memorize the Word of God. Deut. 6:6; Prov. 3:1-3; 7:1-3; Col.3:16.
2. The Bible increases our faith and trust in God. Rom. 10:27; John 20:31.

“There is a vast difference between ‘I have a verse,’ and ‘It has me.’ The one can be the parrot-like repeating of words...the latter the transforming by the renewing of your mind; the daily habit of supplying the subconscious with God’s material to chew upon. What I think about and meditate upon will eventually take on physical form and action. Get into the Book in some plan so the Book will get into you.”

Robert D. Foster The Challenge - a message,

3. The Word of God has been given that we might have victory over sin. Ps. 119:11; 37:31; Matt. 4:1-11
4. Fruit and a successful Christian life is directly related to the Word of God. Josh. 1:8; Ps. 1:2,3.
5. Power to witness and positive results are promised through the use of the Word of God. I Pet. 3:15; Isa. 55:11-13; Acts 4:13,20.
6. Understanding of the Bible will be enlarged. Isa. 28:9,10.
7. The Word Of God will give direction in your life. Isa. 30:21; Ps. 119:105; Ps. 32:8.
8. The Word of God in your life will help you pray more effectively. John 15:7; I John 5:14,15
9. The Word of God has a cleansing effect in a life. Ps. 119:9; John 15:3.
10. The Holy Spirit uses the Word of God to conform us to the image of Christ. II Cor. 3:18.
11. The Word of God will help us in counseling others. Isa. 50:4.
12. The Word of God will impart new joy and positiveness in your daily life. Ps. 119:103; 19:8; Jerm. 15:16.
13. Memorizing Scripture helps in understanding related context verses. John 14:21.
14. There will be little meditation without Scripture memory. Ps. 119:148; 63:1-8; 42:8; I Tim. 4:15; Ps. 49:3
15. Scripture memory is a good way to redeem the time. Eph. 5:16; Col. 4:5.
16. Scripture memory enables us to set an example for others to follow. Phil. 4:9; I Cor. 4:16; 11:1.



**OBEDIENCE**  
I JOHN 2:3

**WHAT?**

1. DOING GOD S WILL FROM THE HEART
2. NOT:  
SERVING GOD ON OUR OWN TERMS  
ASCETICISM  
LEGALISM

**WHY?**

1. BECAUSE OF GOD'S LOVE AND WORTHINESS
2. BECAUSE IT PROVES YOUR LOVE  
I JOHN 5:3
3. BECAUSE GOD DEMANDS IT

**HOW?**

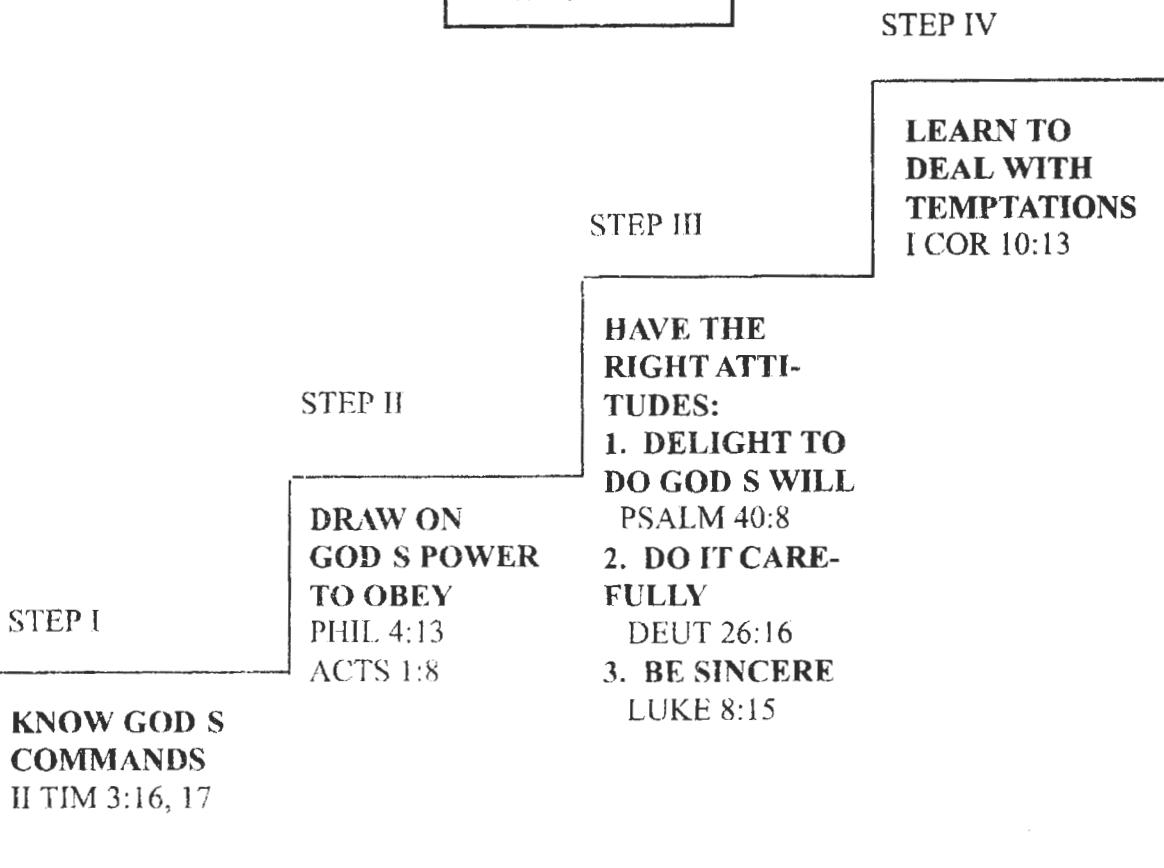

# GOD'S PURPOSE FOR MAN

## **I. God's Original Purpose For Man.**

- A. For His glory - Is. 43:21.
- B. To be in His image - Gen. 1:26.
- C. To have communion with him - Gen. 3:8,9.

## **II. Ways To Glorify God.**

- A. By what we do - I Cor. 10:31; Matt. 5:16.
- B. With our body and spirit - I Cor. 6:19,20.
- C. Bearing fruit - John 15:8.
- D. Praise - Ps. 50:23.
- E. Answered prayer - John 14:13; Ps. 30:1-5

## **III. How To Be "In His Image."**

II Cor. 3:18 - being changed by the Spirit as we are in His presence.

## **IV. Communion With Him.**

God talks to us through the Word and we talk to Him through prayer - Song of Sol. 2:14.

# GROWTH OF THE CHURCH

Acts 2:41-47

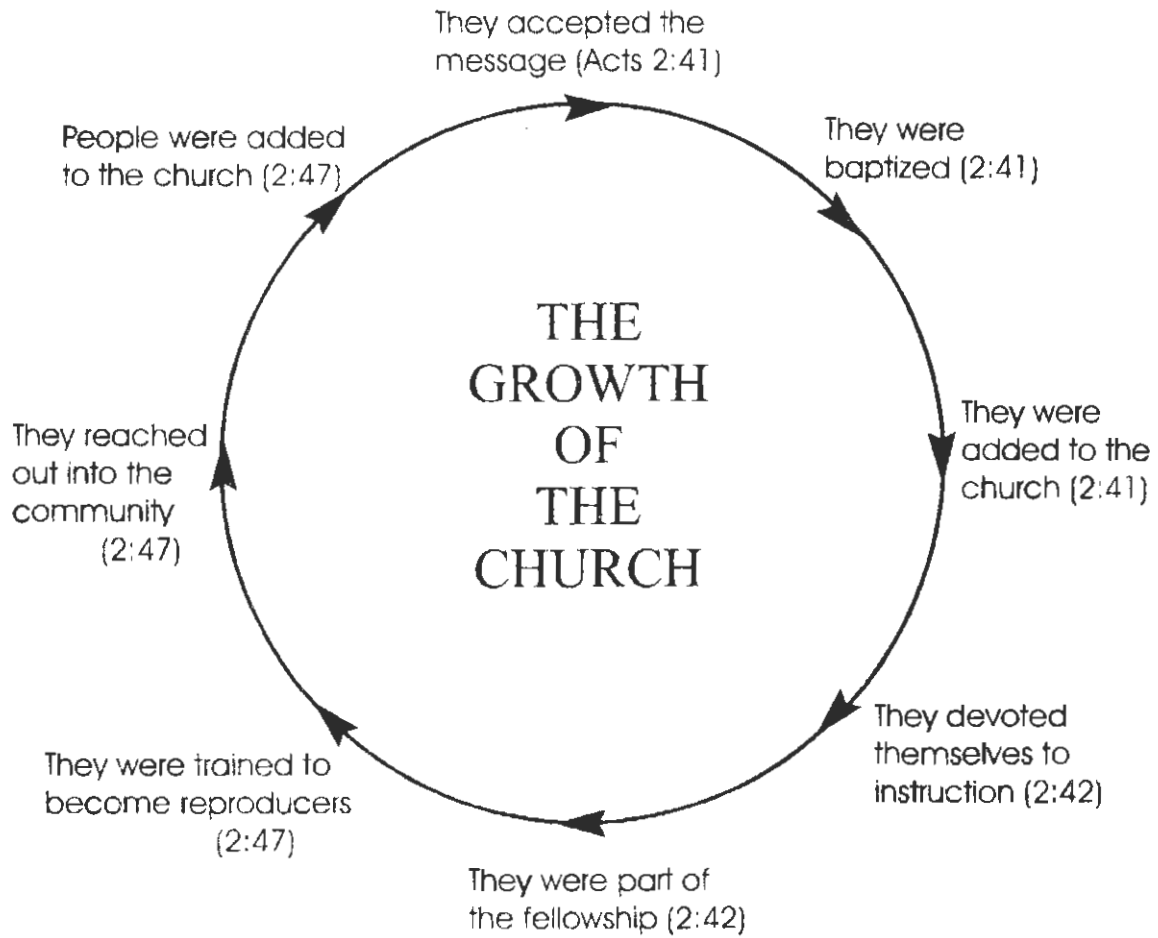

# ----CHECKLIST FOR VICTORY----

Phil 3:1

- \_\_\_\_\_ 1. **Be Sure you Are Saved**  
II Cor. 23:5
- \_\_\_\_\_ 2. **Be Consistent In Devotions And Prayer**  
I Pet. 2:2; Phil 4:6,7
- \_\_\_\_\_ 3. **Be Consistent In Fellowship**  
Heb. 10:24
- \_\_\_\_\_ 4. **Be Sure You Are Filled**  
Eph. 5:18
- \_\_\_\_\_ 5. **Learn To Deal With Sin And Temptation**  
I John 1:9; I Cor. 10:13
- \_\_\_\_\_ 6. **Be Obedient**  
I John 3:22
- \_\_\_\_\_ 7. **Stay In God's Will**  
Col. 3:15; Rom. 12:2
- \_\_\_\_\_ 8. **Become An Effective Witness**  
Acts 1:8
- \_\_\_\_\_ 9. **Learn More Of God's Word**  
Ps. 119; II Tim. 3:16,17
- \_\_\_\_\_ 10. **Live By Faith In Facts, Not Feelings**  
Col. 2:6

**DISCERNING GOD'S  
WILL**

**KEY VERSES**

JER 29:11  
ROM 12:2

1. IT IS GOOD
2. IT IS ACCEPTABLE TO US
3. IT IS FOR OUR WELFARE
4. IT IS PERFECT FOR US

1. **DEFINITE GUIDANCE**  
ISA 30:20,21
2. **GOD GIVES US WISDOM TO FIND IT**  
JAMES 1:5
3. **GOD WILL GIVE US THE DESIRE TO DO HIS WILL**  
PHIL 2:13
4. **BUILT-IN WARNING DEVICE:**  
**PEACE OF CHRIST**  
COL 3:15

**PRACTICAL STEPS TOWARD  
FINDING GOD S WILL**

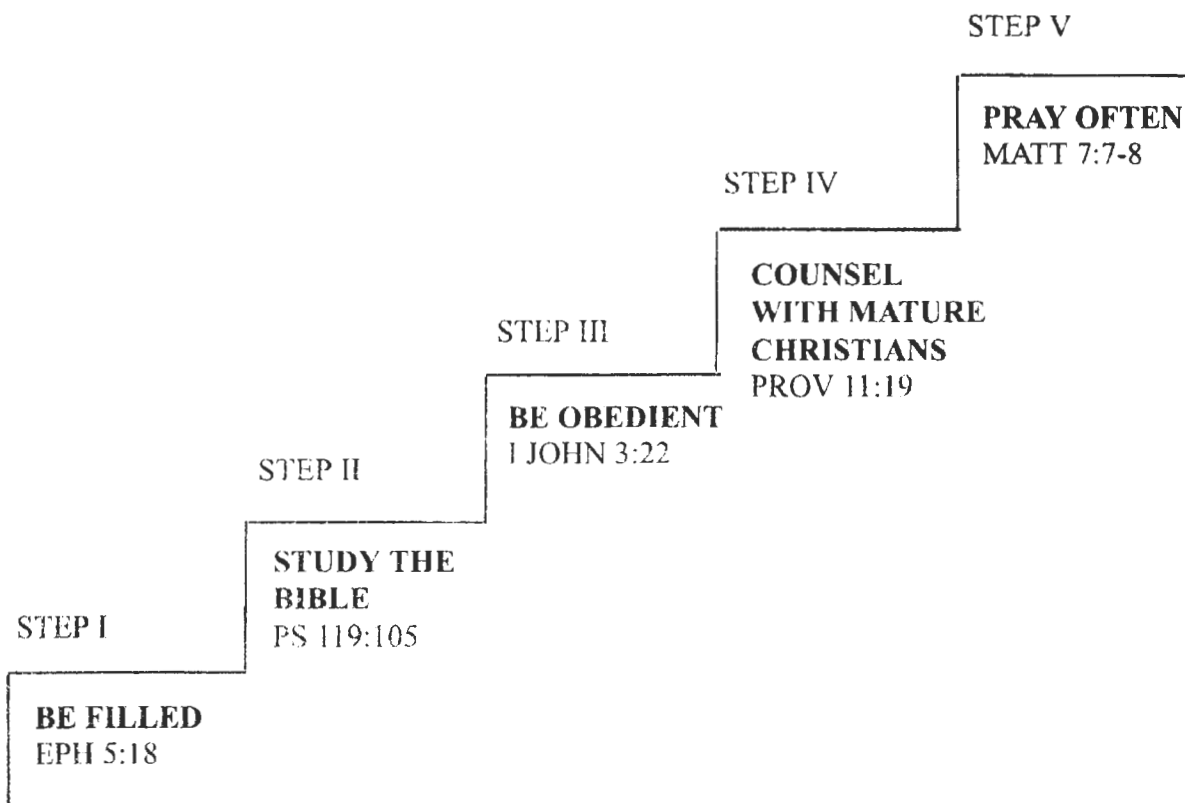

# **WALKING IN THE WILL OF GOD**

(TEACH WHEN EMPHASIZING OBEDIENCE)

## **HINDRANCES TO THE WILL OF GOD**

1. A one-track mind; never reject a man's counsel because some of it is **WRONG**, if some of it is true.
2. Prejudiced counsel. Must be spirit-led in counseling. Jas. 3:1 "Be not many masters..."
3. Unconfessed sin. Prov. 28:13
4. Pride—my right to myself, first 11 chapters of Romans tell us that we're not our own. Rom. 12:12, then says "present yourselves a living sacrifice." I Cor. 6:19,20. Must bring our surrender.
5. Living on past experiences. Get fresh guidance daily. Ps. 143:8.
6. Unwillingness to submit to leadership or authority; ignorance. Prov. 28:9 "turneth ear away from hearing the law."
7. Not expecting God to **GUIDE**.
8. No quiet Time daily: this may be the root of all our other hindrances.

## **HOW TO DISCOVER HIS WILL**

PRINCIPLES IN ACTS 11:5-16

1. Prayer. Vs. 5
2. Through the mind. vs. 6
3. Through God's Word. vs. 7-10
4. Providential circumstances. vs. 11
5. Guidance through the Holy Spirit. vs. 12. Through comparison. vs. 13-15
6. Through Scripture Memory. vs. 16

## **CATEGORIES OF THE WILL OF GOD**

1. Viewpoint of the Will of God. Isa. 55:7-9; Prov. 23:7; II Cor. 10:5
2. Operational will of God—what to **DO**? Must have knowledge.
3. Geographical will - Ex., Jonah, Act. 16:7. Livingston wanted to go to China, war stopped him. Must yield.

## **THE REVEALED WILL OF GOD FOR EVERYONE**

1. It is God's will that every member of the human race be born again. II Pet. 3:9; Romans 12:1,2
2. That all the sanctified - I Thess. 4:3. A Positional-moment of salv. (I Cor. 1:2; Heb. 10:10; Col. 2:10 set apart **IN** Christ Jesus.) B. Experiential sanctification - Eph. 6:26 (fellowship) C. Ultimate sanctification - Phil. 3:21; I Thess. 5:23
3. We must be filled with Spirit - Eph. 5:18
4. That we give thanks in everything - I Th. 5:18
5. That we suffer - I Pet. 3:17
6. That **ALL** trust the Lord - Prov. 3:5,6
7. That every believer be productive - I Pet. 2:15

## PRINCIPLES OF GUIDANCE

1. God always uses His Word. Know what is IN the Book, He never guides contrary to Scripture. Illus. Young school teacher quit her contract before school started to take a job closer to her home. She violated Ps. 15:4
2. God guides us through prayer... as the Spirit makes real a passage or verse of Scripture. "Do you spend at least 5 minutes a day asking God to reveal His will about a pressing matter?" Most do not.
3. A conviction of the Spirit deepens in us. Is. 32:17 "The work of righteousness shall be peace and the effect... quietness forever"
4. He guides through circumstances. (be careful here)
  - a. Through health and wealth
  - b. Through open and closed doors.  
God guides through COUNSEL of others more mature and experienced than yourself committed to the WILL OF GOD, and WHO KNOW US WELL.

1. We must not think that because we want to do something it can't possibly be God's will. God is no kill-joy, trying to take away anything and everything we may enjoy. Jn 4:34.
2. Don't feel every decision you make must have a subjective confirmation.
 

Illus. Daws, riding down road in auto was asked about the will of God; his decisions involved people in the ministry that changed their lives. He said

  - a. "Get all the facts I can.
  - b. Make a list of all the positive and negative reasons for a course of action.
  - c. Pray asking James 1:5 and claiming it.
  - d. By faith make the decision WITH ALL MY HEART. God blesses whole-heartedness above anything else. You can't make a wrong decision with all your heart, doing what I've outlined. God will even take a decision that may not be wise and work it over in circumstances to bless a heart that is wholly His, for His glory."
3. There are logical implications involved in the will of God. Illus. We don't have to be led to marry, then wrestle with God in prayer over whether we are to support the girl we are to marry.
4. God's will is not something necessarily "wild" or "different". Don't be afraid to think, using reason in discovering His will.
5. Watch out against the temptation to "decide what you are going to do". Illus. I'm going to be a businessman and make lots of money and give to God," or "I'm going to be a missionary. "We are to come to the Lord, available, saying to the captain of our salvation, "Here I am, do with me as you will."
6. Watch out that you do not take Bible verses out of context...although He occasionally will.
7. Watch out thinking you're in His will if everything is going smoothly. Frequently when we take a step of faith, the bottom falls out. Illus. Mark 4 - Disciples were told by Jesus to go in boat, a storm came. They cried; He said, "You are faithless and unbelieving." Illus. In Mark 5 Jairus daughter was sick. As Jesus came to heal her, crowd and woman got in way. He was stopped by a woman with medical problem 12 years. Then servant came, "Don't bother Jesus," daughter has already died. Jairus must have been crushed. Following the Lord, and His will and the world caved in. But the Lord said, "Do not fear, only believe." The TEST is not how smooth, but are you fully OBEYING JESUS.
8. Never think that a call to "special service" is something others may not have; all are called. The key question is, "AM I IN THE WILL OF GOD AND SURE OF IT?"
9. Don't make the mistake of thinking that if you do sin and get out of the will of God you are forever thrown on the Lord's junk pile and can never do anything but His SECOND BEST. Illus. John Mark.

HOWEVER, THERE ARE SOME ACTIONS WHICH CHANGE YOUR CAPACITY TO DO CERTAIN THINGS IN GOD'S WILL.

- A. Marriage to the wrong person. Certainly you can't be a foreign missionary with an unsaved husband or wife, or one who refuses to be open to God's will.
- B. You can't teach in college without going to college and getting a degree or accreditation in the subject you teach. Etc.
- C. Most important...the will of God is not a hundred yard dash, it is a daily walk in obedience to what God has already revealed to you. We must get fresh guidance daily; not live in the RUT OF PAST EXPERIENCE ONLY.



# CONDITIONS FOR VICTORY

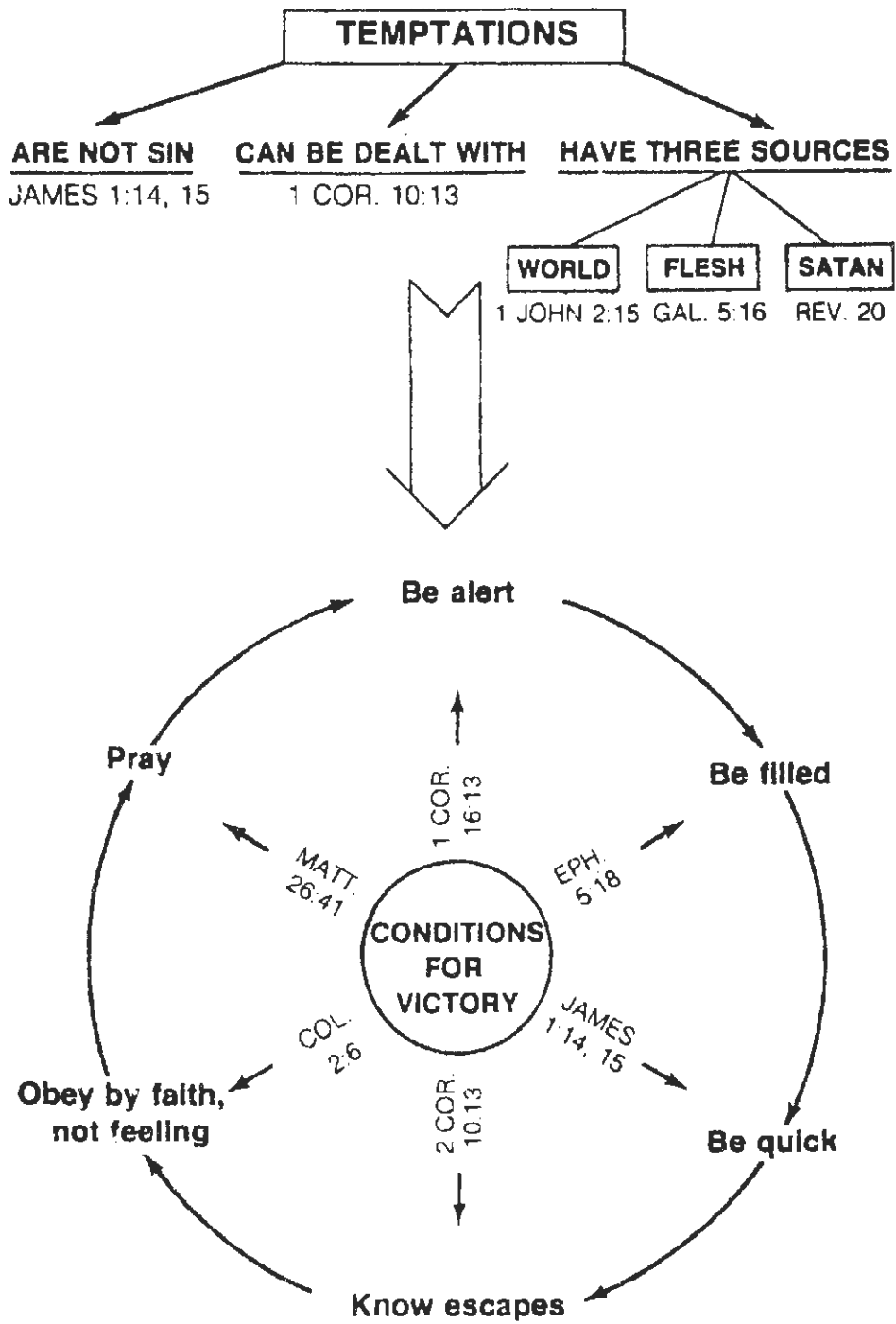

# POWER FOR LIVING

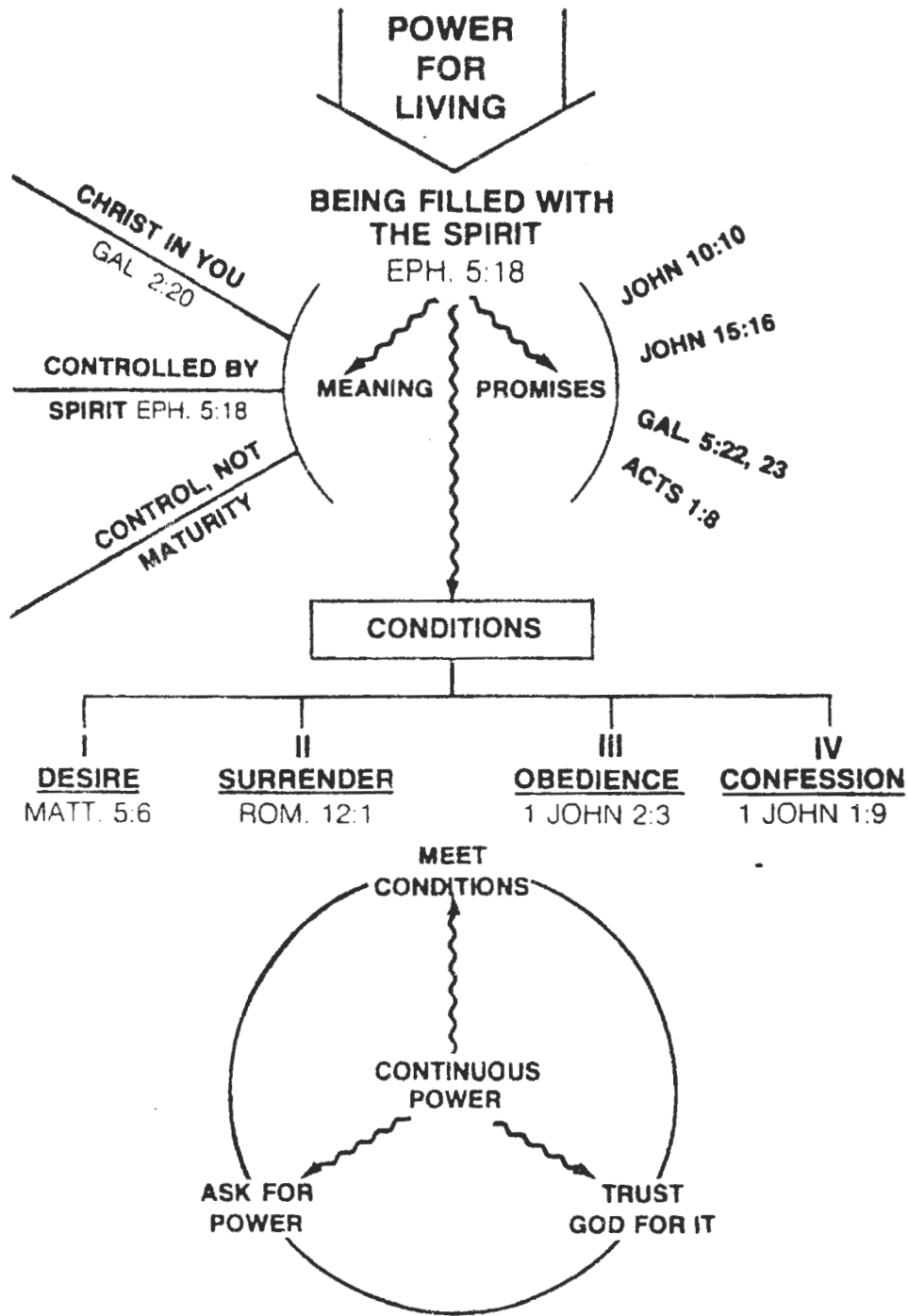

# CRUCIFIXION

Gal. 2:20; 5:24; Rom. 6:6,11

## I. An Unnatural Death.

Self love never dies of itself, it must be killed - Gal. 5:24; 6:14. It must be a very definite act, naming and enumerating what we are putting on the cross.

## II. A Criminal Death.

Crucifixion was only for the worst of offenders. We must see ourselves as deserving the same - Isa. 6:5; Rom. 6:23.

## III. A Painful Death.

Crucifixion is a terrible way to die. The more one resists, the more painful it is - Col. 3:5.

## IV. A Slow Death.

A crucified person could survive up to 3 days. The tyrant of our old natural self may continue to live but we don't have to be dominated by him - James 1:13-15; Col. 3:1-17; Rom. 6:1-23.

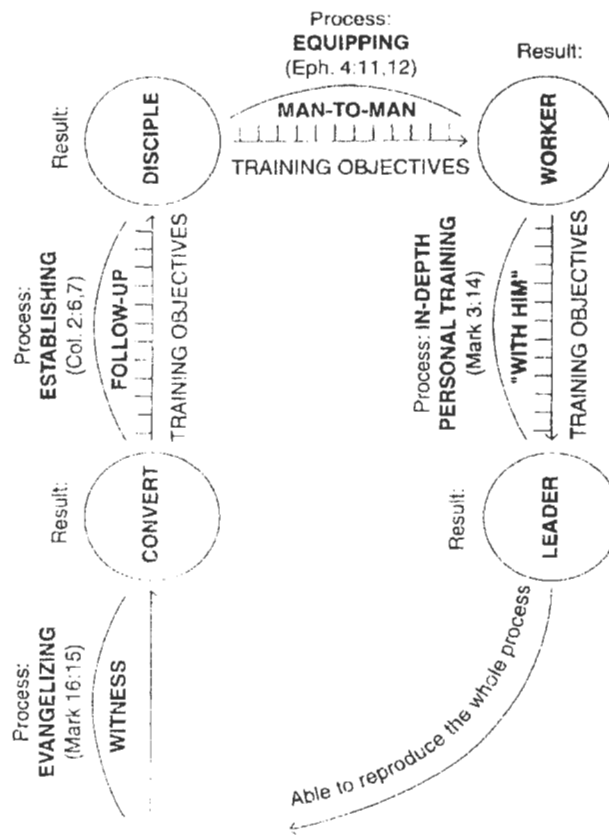

## CHARACTERISTICS OF A PERSON OUT OF FELLOWSHIP WITH THE LORD

Luke 11:26, II Peter 2:20,21; I John 2:18,19. These passages apparently speak of those who have made a profession with the mouth but not with the heart. The real Christian will be punished by God when he falls out of fellowship - Heb. 12:5-8. There are a number of manifestations in the brother who is out of fellowship with God.

1. He has no interest in the Bible even as a sick person has no appetite - I Cor. 3:1,2.
2. He does not want to have fellowship with true believers. If he attends services, it is to cover up his true condition - II Tim. 4:10
3. He has no desire to grow spiritually. Growing in grace does not attract him as before - Heb. 5:12.
4. He has no sense of dependence on God. He feels capable of making his own plans and live as he pleases - James 4:13
5. He is not happy. Although he tries to cover up his true condition, a person out of fellowship with God is unhappy and miserable. If a person can be happy in their sin, this indicates that they have never been born again - Ps. 51:12.
6. He blames his brethren for his miserable condition instead of realizing that it is his own fault. Illustrations: Some boys found an old man sleeping under a tree and as a joke put limburger cheese on his mustache. Upon awaking, he could not find the source of the smell and declared that the whole world stunk. Matt. 7:3
7. Finally, he always excuses himself saying that he has been unjustly treated, or is the victim of circumstances. or that he is more spiritual than other believers.

*Remember: IT IS VERY DANGEROUS.*

1. There is no sin that a person out of fellowship with God cannot commit - Hech. 5:1-11.
2. Just one moment out of fellowship with God can result in a ruined life.

# THE LOST ART OF DISCIPLE MAKING

The wheel illustration is a helpful way to remember the basic truths about the Spirit-filled life. The key to living that life is Jesus Christ as center and Lord of all you do. With Christ in control, life is balanced and effective.

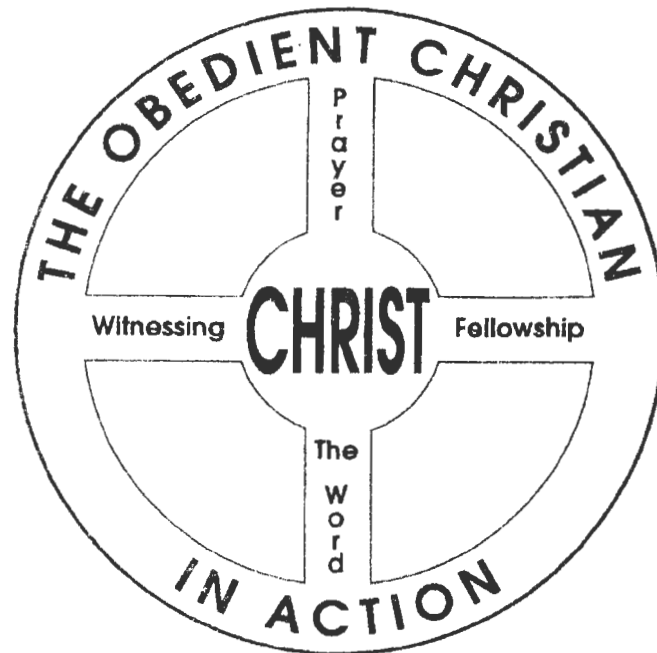

**Christ the Center** (II Cor. 5:17; Gal. 2:20). Just as the driving force in a wheel comes from the hub, so the power to live the Christian life comes from Jesus Christ the Center. He lives in you in the Person of the Holy Spirit, whose expressed purpose is to glorify Christ.

**Obedience** to Christ (Rom. 12:1; John 14:21). The rim represents the Christian responding to Christ's lordship through wholehearted, day-by-day obedience to Him.

**The Word** (II Tim. 3:16; Josh. 1:8). The spokes show the means by which Christ's power becomes operative in your life. You maintain personal contact with God through the vertical spokes - the Word and prayer. The Word is your spiritual food as well as your sword for spiritual battle. It is the foundational spoke for effective Christian living.

**Prayer** (John 15:7; Phil. 4:6,7). Opposite the Word is the spoke representing prayer. Through prayer you have direct communication with your heavenly Father and receive provision for your needs. As you pray, you show your dependence on trust in Him.

**Fellowship** (Matt. 18:20; Heb. 10:24,25). The horizontal spokes concern your relationship to people (believers) through Christian fellowship, and unbelievers through witnessing. Fellowship centered around the Lord Jesus Christ provides the mutual encouragement, admonition, and stimulation you need.

**Witnessing** (Matt. 4:19; Rom. 1:16). The first three spokes prepare you for passing on to others all you have received from the Lord. This is accomplished through witnessing, sharing your own experience of Christ and declaring and explaining the gospel; God's power to save.

# HOW TO HAVE SOMETHING IN HEAVEN WHEN YOU GET THERE

When billionaire Howard Hughes died, everyone wondered how much he left behind. News media did all kinds of reports on all the companies and conglomerates he controlled. Many financial experts were interviewed and speculated on all his dealings. One insignificant, bald headed accountant on the staff of one of his controlling boards said, "He left it all, every red cent. He never took one copperhead with him." However it did not have to be that way.

You have heard of others who spend money like it was going out of style. Being cautioned by some loved one they laugh and say, "you can't take it with you."

However that is not true. You can take it with You!

Or better said, you can send it on before you. Matt. 6:19,20

A man with assets of twelve and one-half million dollars was converted. He read that verse. He thought, "How can I convert my holdings in oil, cattle, land, stocks and bonds into treasure in heaven?" "Are oil or cattle going to heaven?" "NO." "Are stocks and bonds or land going to heaven?" "NO." Who goes to heaven? People - boys, girls, men, and women. He then began to convert his holdings to cash and invested in his church, missions and the message - getting the gospel out. Years later he died - looking forward to seeing the Lord and enjoying heaven.

## I. There Are Two Options For Investment.

- A. This world's system.
  - 1. John 17:14-17.
  - 2. Col. 3:1-4.
  - 3. Rom. 12:2.
- B. The world and all that is in it will be destroyed.
  - 1. Peter spoke of this event in II Pet. 3:10.
  - 2. This age of Grace and opportunity could end any minute.
- C. Which system are you going to invest in?
  - 1. One system declares that there is no danger of losing one's investment. There will be no thief to steal. There is no loss of value due to wear or deterioration. The smallest investment will be remembered and rewarded (even giving a cup of water)
  - 2. One system will not survive. All there is will be completely lost or destroyed.
  - 3. Which system would you believe a financial consultant would recommend investing in - a growing one with a bright future, or one that is doomed to bankruptcy, failure and total loss.
  - 4. It is your money and your life! You have the power of decision. You will or are already making the choice.

**II. Prosperity Promised To Those Who Give Liberally.** Mal. 3:10; Prov. 3:9,10; 11:25; Luke 6:38; II Cor. 9:6.

- A. God is the owner of everything.
- B. Anything we have is only loaned.
- C. We can enter into partnership with the Lord.
- D. No one pays like the Lord.

**III. The Temptation Not To Give Liberally.**

Satan uses many methods to keep us from giving.

- A. Our natural desire to covet. We do not have to be taught to be selfish; it is our nature.
  - 1. Coveting is a so-called respectable sin.
  - 2. The Dr. Jekyll - Mr. Hyde.
    - a. To man it seems nice, acceptable, a harmless practice
    - b. To God it is addicting - enslaving one's will - alienating one's love - robbing one's purpose.
  - 3. Coveting is behind all sin. 1 Tim. 6:10.
- B. The natural tendency to walk by faith - as long as we can see where we are going.
  - 1. Can't tithe because of our bills - can't afford to.
  - 2. We'll start tithing when things get better.
  - 3. "I'm not going to give to that preacher or that church." Give to God.
- C. A natural tendency to doubt.
  - 1. It won't do any good to tithe anyway. Mal. 3:14.
  - 2. God's cure for a stingy, selfish, coveting spirit is to accept the promises of God literally and give. He will honor His Word by giving more back to you.

**IV. Tithing Is Taught Throughout The Bible.** Gen. 14:20; 28:22; Lev. 27:30; Heb. 7:2,6.

- A. Tithing was taught before the law. Gen. 14:20.
- B. Jacob tithed 400 years before Moses lived. Gen. 28:22.
  - 1. All Israelites were commanded to tithe. Lev. 27:30-33.
  - 2. The tithe was used to support the Levites and the Temple service. Num. 18:21-32.
  - 3. Additional tithes were required at certain times. Deut. 12:5-18; 14:22-29.
  - 4. There were penalties charged for cheating on their tithes. Lev. 27:31.
  - 5. The Pharisees tithed even on herbs. Matt. 23:23.
  - 6. The tithe in the Old Testament acknowledged and glorified God. Mal. 3:8-12.
    - a. Scriptural - "Bring ye all the tithes." - God has never relinquished His claim on the tithe as the minimum of one's gift.
    - b. Simple - "Bring" - Just as simple as going to church.
    - c. Serviceable - "Into the storehouse." - The church is God's storehouse into which all the tithe is to be brought.
    - d. Sufficient - "That there may be meat in mine house." - "Meat" refers to sufficient
    - e. Sublime - "Prove me now herewith." - "Prove" means: to give God a chance - to accept God's challenge. God yearns for a chance to bless His people.

- f. Sensible - "If I will not open you the windows of heaven and pour you out a blessing that there shall not be room enough to receive it." - God obligates Himself to obedience.
  - g. Satisfying - "And all nations shall call you blessed: for ye shall be a delightsome land."
- C. Jesus practiced tithing.
- 1. He fulfilled the law. Matt. 5:17,18.
  - 2. Commanded tithing. Matt. 23:23; Luke 11:42.
  - 3. Christ always practiced what He preached.
- D. Paul taught that New Testament ministry was to be supported in the same manner as was the Levitical ministry.
- 1. Paul taught on the importance of giving. I Cor. 9:7-14.
    - a. Does a soldier pay his own salary while in the army? v.7a.
    - b. Does a farmer plant grapes and not eat of the grapes? v.7b.
    - c. Does a herdsman not partake of the flock? v.7c
    - d. Does an ox not eat of the corn? v.9
  - 2. The spiritual realm of giving. Paul said that everyone who worked in the physical were partakers of the fruit of their labors - then he applied the same principle to the spiritual. v.11.
  - 3. An illustration of supporting the ministry. v.13.
  - 4. "Even so." v. 14 - means in the same manner or in the manner previously described and mentioned
- E. We cannot give an offering until we have tithed. I Cor. 16:1,2; II Corinthians chapters 8 and 9.

**V. Giving Scripturally Is Proof Of Our Understanding Of True Stewardship. ("A trust granted for profitable use.")**

- A. God entrusts to us certain "goods". Luke 16:2.
- B. Faithfulness in its use is God's criteria. I Cor. 4:2.
- C. All the "goods" we may have are just loaned. Ps. 24:1; Rom. 14:8; Luke 16:2
- D. If we are faithful in that which is least in the sight of God, He will entrust greater things to us. Luke 16.10,11.



## THE PIE ILLUSTRATION

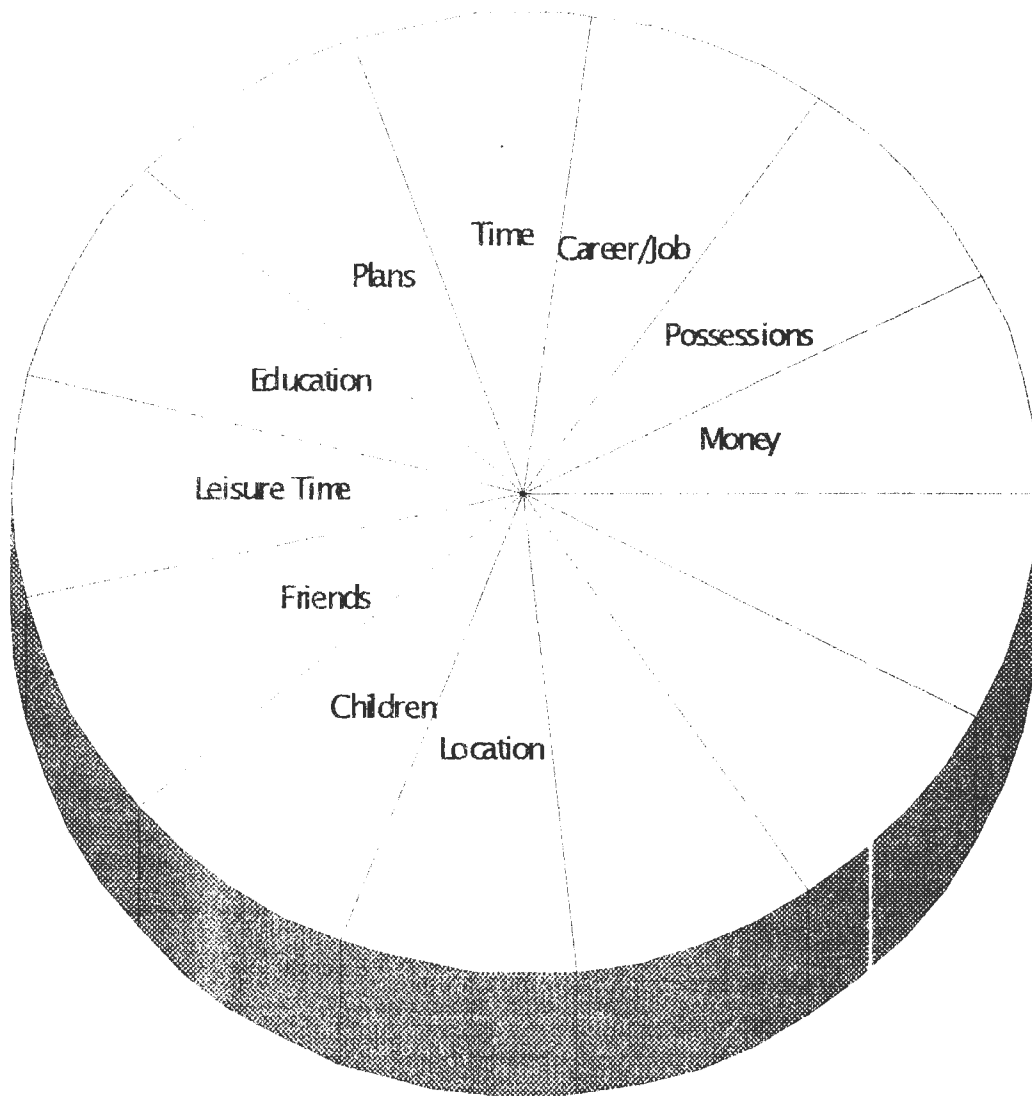

The Pie Illustration Communicates the issue of the Lordship of Christ. Each segment of the "pie" represents a major area of our life where there is often a struggle over who will control it - self or the Lord Jesus Christ. For each of these areas ask the question, "Is Jesus Christ Lord?" Are you truly seeking God's will or are you just asking God to rubber-stamp your plans? Note the blank spaces in the illustration. This is for you to fill in areas not listed - areas that may be a special battle zone for you in this issue of Lordship. It could be the area of appearance or clothes or food and drink!

# HOW TO DOUBLE YOUR LIFE EFFECTIVENESS

By Waylon Moore  
Eph. 5:16

Time: The raw material of life itself. The management of time is the management of ourselves. It can be "redeemed" (bought) and made eternal only if we are "filled with the Spirit" (Eph. 5:15-18). It is not how much we do that counts; it is how much we get done. Activity is no substitute for production. There are enough hours in the day to fulfill all God's will for your life. We never need more time than we have to do the will of God today. "It's not the days in your life, but the life in your days that count"- Adlai Stevenson. Jesus' priorities reflected His instant obedience to the Father and sensitiveness to those around Him and their needs. Jesus said, "I must work the works of Him that sent me while it is day, the night cometh when no man can work" (John 4:34). Yet He was never in a hurry, never late. He summarized His life before dying with "I have finished the work which thou gavest me to do" (John 17:4).

## How to get control of your life.

Surrender all you know of yourself, your dreams, your future to Christ. This surrender should be confirmed before God anew each day. Rom. 12:1,2.

1. Ask yourself and write down specifically answers to these three questions.
  - a. What are my lifetime goals?
  - b. How would I like to spend the next three years?
  - c. If I knew I had only six months to live, or only six months to serve Christ where I am, how would I live until then.

Meditate: What would you do differently, change or reemphasize that is not now priority in your life? Prayerfully seek the Lord. Then list. Review; share with your mate or someone. Ask God for verses to strengthen what He is leading you to be and do. **GOD IS MORE INTERESTED IN WHAT A PERSON IS THAN IN WHAT A PERSON DOES.**

The lasting quality of our life flows from our relationship to Christ daily.

2. Write down the 6 most important things you need to do tomorrow. Then number them in order of importance. First thing in the morning, begin immediately on item one, keep at it until it is finished. Then tackle item two, and so on. If interrupted, in prayer, surrender the circumstances to the Lord and rest in His love, return to your priorities when next possible. Isaiah 26:3.
3. Schedule your most important tasks, etc. at the time of day best for you. Are you an AM or PM person?
4. Ask yourself, "Is this urgent or only important?" Claim the Spirit's guidance. John 14:26,27.

5. Reorganize your desk. Place in order of priority. Some things really may not be important. Weigh the importance. If overwhelmed, do what you do not like first. It may not be necessary to be a "perfectionist."
6. Learn what are your gifts. You cannot do it all. Say "NO" and smile. We may be over committing because of fear or ego needs.
7. Use uncommitted time. Preplan! Never "Wait" for someone or something again. Review your memory verses! Read your Bible! Pray! Read a book! Play cassettes as you travel. Meditate!
8. Balance your day with other activities. Review your priorities. Time with the Lord, wife, children, key men, witnessing

## FIVE PEGS FOR SCHEDULING TIME

1. **OBJECTIVES** - Put in writing in your notebook. Need to be clear - obtainable - realistic. (My life, family, ministries). Summarize the facts; desired goal when accomplished; set a date to accomplish objectives.
2. **OPPORTUNITIES**
3. **RESOURCES** - Your main human resource is people. Ask, what other resources do I have to invest in those opportunities? Time? Money? Others?
4. **ACTIVITIES** -
  - (1). My personal relationship with the Lord.
  - (2). The Spiritual welfare of my family.
  - (3). The work of the ministry entrusted to me.
  - (4). Paul; a lawyer by education; tentmaker by trade; Apostle by calling
5. **TIME TABLE** - Be realistic. You must have some way to measure progress.

# DISCIPLESHIP PRECEPTS

## ORGANIZATION

There may be nothing wrong with you,  
The way you live, the work you do,  
But I can very plainly see  
Exactly what is wrong with me  
It isn't that I'm indolent  
Or dodging duty by intent;  
I work as hard as anyone,  
And yet I get so little done.  
The morning goes, the noon is here,  
Before I know, the night is near,  
And all around me, I regret,  
Are things I haven't finished yet.  
If I could just get organized!  
I oftentimes have realized  
Not all that matters is the man;  
The man must also have a plan.

With you, there may be nothing wrong,  
But here's my trouble right along;  
I do the things that don't amount  
To very much, of no account.

That really seems important though  
And let a lot of matters go.  
I nibble this, I nibble that,  
But I never finish what I'm at.  
I work as hard as anyone,  
And yet I get so little done,  
If I could just get organized!  
I'd do so much you'd be surprised,

## DISCIPLESHIP PRECEPTS

My brain may be the storage house  
Of vast, unmeasurable thought,  
But without pen and paper  
The data would be lost.  
I may know all, but all I know  
Would not be worth a dime  
Without a pen to write it down,  
It'd slip my crowded mind  
Just 10% of what I read  
Will barely be retained.  
20% of what I hear  
Will occupy my brain.  
Just 30% of what I see  
Days later can be found.  
My memory box is handicap,  
And so I'll write it down!

Rebekah Pearl  
May '96 Bowie Workshop

# THE SEVEN GIFTS OF ROMANS 12

## SPIRITUAL GIFTS - CHARACTERISTICS

### I. PROPHECY -- (Peter, very open).

- A. Quick judgements -- on right and wrong.
- B. Ability to sense dishonesty, reacting harshly.
- C. Openness about personal faults; honest.
- D. Impulsive, painfully direct, persuasive.

#### Negative:

- 1. Correcting, jumping to conclusions, condemning spirit.
- 2. Dwelling on the negative, lacking tact.
- 3. Self condemnation' demanding response to rebuking.

### II. SERVING -- (Timothy)

- A. Ability to see practical needs and meet them.
- B. A joy in serving -- so that you disregard health.
- C. Meeting physical needs
- D. Enjoys short-range projects.
- E. Needs appreciation to confirm service.

#### Negative:

- 1. Neglects home responsibilities.
- 2. Goes around proper authority to do job
- 3. Takes too many jobs; wears out physically
- 4. Becomes hurt when others aren't grateful.

### III. TEACHING -- (Luke)

- A. Checks out statements to see if true.
- B. Wants to get credentials from speaker.
- C. Alert to detail -- loves to research, get facts.

#### Negative:

- 1. Can be knit-picky.
- 2. Detailed.
- 3. Can be proud of knowledge; critical of practical application.
- 4. Bore listeners with minute details.

### IV. EXHORTATION -- (Paul)

- A. Motivated to urge growth to maturity.
- B. Desires to give precise steps to growth.
- C. Wants to explain truth logically.
- D. Loves face-to-face discussion; wants a decision.
- E. Identifies with people of different backgrounds.

#### Negative:

- 1. Takes "family time" to counsel-help others.
- 2. Treats family and friends as projects...
- 3. Takes on new jobs without finishing old ones.
- 4. Raises expectations of others; they "sell" well.

5. Trusts visual results rather than heart change.
6. Neglects doctrines; counsels others before having the facts.

**V. GIVING -- (Matthew)**

- A. Discern wise investment opportunities; makes money.
- B. Wants to give quietly; gives quality gifts.
- C. Sees financial needs others overlook.
- D. Alert to see what others do with money.
- E. Responds slowly to emotional appeals.

**Negative:**

1. Chinchy with own family; listens to unscriptural counsel about money. Puts pressure on those who can't afford to give.
2. Tends to seek to control with money; invests where peoples lives aren't changed; projects, not needs.

**VI. ADMINISTRATION -- (Nehemiah)**

- A. Visualize final results; can break down task to small units.
- B. Organize.
- C. Ignores distracting details
- D. Can delegate well; ability to inspire, encourage.

**Negative:**

1. Views people as resources rather than people.
2. Uses people; delegating too much work on others.
3. Unresponsive to suggestions
4. Failure to give proper explanations - overlooks faults of people.

**VII. MERCY -- (John)**

- A. Sense genuine love.
- B. Need for deep friendships.
- C. Mental rather than physical needs.
- D. Removes causes of hurt.
- E. Attracts people with mental-emotional distresses.
- F. Tendency to avoid decisions and firmness.
- G. Very accepting.

**Negative:**

1. Not firm.
2. Takes up offenses.
3. Decides emotionally.
4. Attracted to prophecy gift.
5. Attracts others of opposite sex -- possessive friendships.
6. Judges these not sensitive.
7. Sometimes has great sympathy with those who are violating God's principles.



# MY SPIRITUAL INVENTORY

“Remember His marvelous works that He hath done, His wonders, and the judgments of His mouth.” 1 Chronicles 16:12.

Take a few minutes to meditate on each point, then prayerfully ask the Lord what you should write down

## THE PAST

1. List the greatest blessings from this past year:
  - a. In your family:  
\_\_\_\_\_  
\_\_\_\_\_
  - b. In your work:  
\_\_\_\_\_  
\_\_\_\_\_
  - c. In your personal life:  
\_\_\_\_\_  
\_\_\_\_\_
2. What was the greatest trial and what have you learned from it?  
\_\_\_\_\_  
\_\_\_\_\_
3. List in order the best of your answers to prayer in the year gone by.
  - a. \_\_\_\_\_
  - b. \_\_\_\_\_
  - c. \_\_\_\_\_
  - d. \_\_\_\_\_
4. List any past happenings or circumstance you do not understand. Then read Deut. 29:29; Prov. 3:5,6; Ecc. 3:14.  
\_\_\_\_\_  
\_\_\_\_\_
5. List a specific lesson the Lord taught you last year  
\_\_\_\_\_  
\_\_\_\_\_

What you are praying and studying now is what you are going to be for God.

## CHECK UP

Do you have regular victory in:

- a. Your devotional life? Yes \_\_\_\_\_ No \_\_\_\_\_
- b. Your attitudes? Yes \_\_\_\_\_ No \_\_\_\_\_
- c. Control of tongue, anger? Yes \_\_\_\_\_ No \_\_\_\_\_
- d. Doing God's will? Yes \_\_\_\_\_ No \_\_\_\_\_
- e. Leading your children in devotions? Yes \_\_\_\_\_ No \_\_\_\_\_
- f. Appetites of your body, eyes, etc.? Yes \_\_\_\_\_ No \_\_\_\_\_

TO DO ON JANUARY 1<sup>st</sup>

1. What is on your priority list for this year in regard to:

A. Your personal life?

- 1. \_\_\_\_\_
- 2. \_\_\_\_\_
- 3. \_\_\_\_\_

B. Your family?

- 1. \_\_\_\_\_
- 2. \_\_\_\_\_
- 3. \_\_\_\_\_

C. Your work and ministry?

- 1. \_\_\_\_\_
- 2. \_\_\_\_\_
- 3. \_\_\_\_\_

2. What prayer or personal goals do you have now? What is God saying to you these days about this year?

- A. \_\_\_\_\_
- B. \_\_\_\_\_
- C. \_\_\_\_\_
- D. \_\_\_\_\_

Phil. 4:13; Rom 8:32,37; Matt. 28:18,19.

# CHRISTIAN GIFT IDENTIFICATION KIT

Score yourself on a scale of 4 - Much like you - to 0 - Rarely like you.

Put number answers in appropriate boxes. Add to right.

	TOTAL							
ROW A	1	8	15	22	29	36	43	A _____
ROW B	2	9	16	23	30	37	44	B _____
ROW C	3	10	17	24	31	38	45	C _____
ROW D	4	11	18	25	32	39	46	D _____
ROW E	5	12	19	26	33	40	47	E _____
ROW F	6	13	20	27	34	41	48	F _____
ROW G	7	14	21	28	35	42	49	G _____

These seven motivational gifts are in Romans 12:4-8,  
 A - Prophecy, B - Serving C - Teaching D - Exhortation E - Giving  
 F - Organization G - Mercy

## HINDRANCES TO DISCOVERING YOUR SPIRITUAL GIFTS

1. Unresolved root-problems in personal living.
2. Lack of involvement with the needs of others: Our gifts are "stirred up" and discovered as we focus on the needs of others, rather than what our ministry is to be. A servant's heart is essential to discover your gift.
3. Attempts to imitate motivations of others.
4. Failure to analyze why certain activities appeal to appeal to us. We need to understand what the basic motivation is for our present Christian activities. Many activities will be the means of fulfilling our basic motivation.
5. Confusion between motivational and ministry gifts. Remember: We all exercise functions involved in the 7 motivational gifts; however, we have ONE of these as our basic gift from the Spirit.

